

1 **FITZGERALD MONROE FLYNN PC**

2 JACK FITZGERALD (SBN 257370)

3 *jfitzgerald@fmfpc.com*

4 MELANIE R. MONROE (SBN 275423)

5 *mmonroe@fmfpc.com*

6 TREVOR FLYNN (SBN 253362)

7 *tflynn@fmfpc.com*

8 PETER GRAZUL (SBN 342735)

9 *pgrazul@fmfpc.com*

10 2341 Jefferson Street, Suite 200

11 San Diego, California 92110

12 Phone: (619) 215-1741

13 ***Counsel for Plaintiffs***

14 **UNITED STATES DISTRICT COURT**
15 **CENTRAL DISTRICT OF CALIFORNIA**

16 NAEEM AZAD and MIHAI CALUSERU,
17 on behalf of themselves, all others similarly
18 situated, and the general public,

19 Plaintiffs,

20 v.

21 CAITLYN JENNER and SOPHIA
22 HUTCHINS,

23 Defendants.

Case No: 2:24-cv-9768

CLASS ACTION

**COMPLAINT FOR VIOLATIONS OF
THE SECURITIES ACT AND FRAUD**

DEMAND FOR JURY TRIAL

1 Plaintiffs NAEEM AZAD and MIHAI CALUSERU, individually, and on behalf of all
2 others similarly situated, bring this action against Defendants CAITLYN JENNER and
3 SOPHIA HUTCHINS and allege the following upon their own knowledge, or where they
4 lack personal knowledge, upon information and belief, including the investigation of their
5 counsel.

6 INTRODUCTION

7 1. Beginning on May 26, 2024, Jenner, a high-profile international celebrity and
8 former Olympic gold-medalist, aided by her business partner and manger, Hutchins,
9 orchestrated a scheme wherein she offered and sold unregistered securities – the
10 cryptocurrency,¹ \$JENNER – and fraudulently solicited financially unsophisticated investors
11 throughout the United States and abroad to purchase the unregistered securities, in violation
12 of federal and state law.

13 2. \$JENNER is a type of cryptocurrency known as a “memecoin.” A memecoin is
14 a type of blockchain-based digital asset that draws its inspiration from memes, characters,
15 trends or, as in this case, the social media accounts and online presence of celebrities.
16 Memecoins typically experience monumental increases and decreases in value and price in
17 an exceptionally short periods of time, so that their underlying values soar and crash based
18 on internet culture and viral moments rather than any tangible fundamentals.

19 3. Unlike other cryptocurrencies, such as Bitcoin, the overwhelming majority of
20 memecoins, including \$JENNER, are not decentralized, have little to no utility or
21 functionality, and are used neither as a store of value nor a medium of exchange. A memecoin
22 derives its value, instead, from the success or failure of its issuer or promoter to attract and
23 sustain community engagement in the project. Investors purchase memecoins with the hope
24

25 ¹ “Cryptocurrency” refers to a group of digital assets whose transactions are secured and
26 verified using cryptography – a scientific practice of encoding and decoding data. Those
27 transactions are often stored on computers distributed throughout the world via a distributed
28 ledger technology called blockchain. The terms “cryptocurrency,” “digital asset,” “coin,” and
“token” are used interchangeably throughout this complaint.

1 that the underlying price will increase in the future as the project grows in popularity, based
2 upon the managerial, entrepreneurial, or promotional efforts of the creator, promoter, issuer,
3 other associated persons or active participants.

4 4. Because this type of digital asset is properly classified as a security under federal
5 and California law, before offering \$JENNER for sale to the public, Jenner was required to
6 file registration statements with the United States Securities and Exchange Commission, and
7 to comply with all federal and state securities laws, which she willfully failed to do.

8 5. Jenner has used her various public social media accounts, which are followed by
9 millions of people, as well as other media outlets, such as podcasts and public statements, to
10 promote \$JENNER to investors and to solicit their purchases, ultimately defrauding Plaintiffs
11 and the Class. Since commencing the scheme, Jenner has continuously, systematically,
12 directly, and repeatedly touted \$JENNER's ability to increase in value based on her
13 managerial and entrepreneurial efforts, thereby manipulating the market and overall valuation
14 of Jenner's own cryptocurrency, serving her own financial interests.

15 6. In fact, Jenner's primary purpose in creating \$JENNER was to cross-promote
16 herself and her ventures, and to cultivate a cryptocurrency brand uniquely associated with
17 herself, which she could easily manipulate, which she in fact did manipulate.

18 7. As a direct result of Jenner's fraudulent offer for sale and sale of these
19 unregistered securities, Plaintiffs and the Class – many of whom are retail investors and lack
20 the technical and financial sophistication necessary to have evaluated the risks associated
21 with their investment in \$JENNER, and were denied the information that would have been
22 contained in the materials required for the registration of \$JENNER – have suffered
23 significant damages.

24 **JURISDICTION AND VENUE**

25 8. This Court has subject matter jurisdiction over this action pursuant to 28 U.S.C.
26 §§ 1391 and 1367(a), because Plaintiffs' claims under the Securities Act raise federal
27 questions; and the Court has supplemental jurisdiction over Plaintiffs' claims under
28 California state law.

1 9. This Court has personal jurisdiction over Defendants because Defendants are
2 residents of this District and have substantial contacts with this District.

3 10. Venue is proper in this District pursuant to 28 U.S.C. §§ 1391(b) and (c) because
4 Defendants are subject to the Court’s personal jurisdiction herein. Furthermore, the acts
5 giving rise to Plaintiffs’ claims occurred, among other places, in this District.

6 **PARTIES**

7 11. Plaintiff Naeem Azad is a citizen of the United Kingdom and relied on Jenner’s
8 false and misleading statements and omissions when investing in \$JENNER on both the
9 Solana blockchain and Ethereum blockchain. As set forth in the accompanying Certification
10 attached as Exhibit 1, Azad first purchased \$JENNER on the Solana blockchain on May 26,
11 2024, and on the Ethereum blockchain starting May 31, 2024. Azad has subsequently lost at
12 least \$25,000 between both versions of \$JENNER. Had it not been for the false and
13 misleading statements and omissions made by Jenner, Plaintiff Azad would not have invested
14 in or held \$JENNER.

15 12. Plaintiff Mihai Caluseru is a citizen of Romania and a resident of Portugal who
16 relied on Jenner’s false and misleading statements and omissions when investing in
17 \$JENNER on both the Solana blockchain and Ethereum blockchain. As set forth in the
18 accompanying Certification attached as Exhibit 2, Caluseru first purchased \$JENNER on the
19 Solana blockchain on May 26, 2024, and then again on the Ethereum blockchain starting on
20 June 3, 2024. Caluseru estimates total losses of at least \$31,000 between both versions of
21 \$JENNER. Had it not been for the false and misleading statements and omissions made by
22 Jenner, Caluseru would not have invested in or held \$JENNER.

23 13. Defendant Caitlyn Jenner is an internationally recognized media personality and
24 former Olympic gold medal-winning decathlete. Jenner is the primary promoter, offeror, and
25 seller of \$JENNER. Upon information and belief, during the relevant time period, and
26 continuing today, Jenner was a resident and citizen of California, living in Calabasas,
27 Thousand Oaks, or Malibu, California.

1 14. Defendant Sophia Hutchins is a businesswoman, television personality, and
2 CEO of the sunscreen company LUMASOL. She is Jenner’s manager and business partner.
3 Hutchins was also the CEO of the \$JENNER project and acted as a promoter, manager, and
4 control person for the enterprise, as well as for \$JENNER itself. Upon information and belief,
5 during the relevant time period, and continuing today, Hutchins was a resident and citizen of
6 California, living in Malibu, California.

7 **BACKGROUND AND RELEVANT FACTS**

8 ***Blockchain Technology***

9 15. A public blockchain is a digital ledger containing information (such as records
10 of financial transactions) immediately available to any member of the public.² Unlike
11 traditional ledgers, which are managed and validated by a centralized authority, public
12 blockchains are distributed and decentralized. This structure offers greater transparency as to
13 ownership by being based on consensus as to the accuracy of the transactions consummated
14 on the network. To reach consensus, embedded in each blockchain platform is a software
15 protocol, or consensus mechanism, which provides governance standards over how
16 information is added to the blockchain.

17 16. Blockchain-based transactions are considered more secure and trustworthy than
18 ledgers controlled by centralized authorities, like banks, because adding, changing, or
19 removing information from the blockchain is made purposefully difficult, so that it is harder
20 to falsify a transaction or hack into the ledger itself.³

21
22 ² See Jonathan Rohr & Aaron Wright, *Blockchain-based Token Sales, Initial Coin Offerings,*
23 *and the Democratization of Public Capital Markets*, 70 HASTINGS L.J. 463, 469 (2019) (“At
24 their core, blockchains are decentralized databases maintained by a network of computers.
25 Using public-private key cryptography and strict code-based rules – known as consensus
mechanisms – blockchains store tamper-resistant, resilient, and authenticated data, enabling
users to engage in pseudonymous transactions.”).

26 ³ *Id.* at 471 (“[B]lockchain-based consensus mechanisms make adding information to a
27 blockchain purposefully difficult and even harder to remove once saved, creating data that is
28 hard to alter once stored. Blockchain-based protocol groups sets of transactions into blocks,
which are linked together to form a sequentially ordered chain. Before a block can be added

1 17. Unlike a bank that exercises complete control over validating any transaction on
2 its ledgers, transactions on decentralized blockchains must be validated by a network of users.
3 To encourage validation of the transactions on a blockchain, validators (sometimes
4 colloquially referred to as “nodes,” or “miners”) are provided incentives, often in the form of
5 cryptocurrency. Blockchain transactions are typically validated through “Proof of Work” or
6 “Proof of Stake” methods.

7 18. For example, Bitcoin, whose “cashtag”⁴ is \$BTC, operates on a “Proof of Work”
8 blockchain. To generate a new “hash” (or ledger entry) for a block of transactions on the
9 Bitcoin blockchain, validators engage in a mathematical (*i.e.* cryptographic) guessing game
10 requiring their computers to, through brute-force computing, guess the answer to an
11 algorithm. The validator who wins the guessing game broadcasts the new hash to the network
12 and, once confirmed by the other validators, is rewarded with \$BTC for their efforts.

13 19. “Proof of Stake” blockchains require much less energy than “Proof of Work”
14 blockchains, making them desirable for projects and protocols looking to scale quickly.
15 “Proof of Stake” requires validators to “stake,” or lock up, cryptocurrency they already own.
16 Validators staking more cryptocurrency for longer periods of time have the greatest chance
17 of being selected by an algorithm to validate new transactions, much like a lottery system.
18 Once new transactions are validated, the validator earns the blockchain’s particular
19 cryptocurrency as a reward.

20 20. Since Bitcoin’s introduction in 2009, blockchain technology and use cases have
21 grown exponentially via the creation of various cryptocurrencies, smart contract protocols,
22 decentralized finance (“DeFi”), decentralized applications (“DApps”), and decentralized
23 exchanges (“DEXs”).

24 _____
25 to a blockchain, the protocol requires that a valid cryptographic hash for a block (an encrypted
26 representation of the underlying transactional data) is generated.”).

27 ⁴ A cashtag is a Twitter (X) feature allowing users to click on ticker symbols to search specific
28 cryptocurrencies and digital projects. The feature allows social media users to easily search
for posts related to the cryptocurrency, similar to a ticker for a publicly-traded company.

1 21. Many blockchains have emerged to provide smart contract functionality. Smart
2 contracts generally refer to small applications stored on a blockchain and executed in parallel
3 by a large set of validators. In the context of public blockchains, the network is designed so
4 that each participant can be involved in and verify the correct execution of any operation.
5 Smart contracts will always be executed as specified and allow anyone to verify the resulting
6 state changes independently. When implemented securely, smart contracts are highly
7 transparent and minimize the risk of manipulation and arbitrary intervention.

8 22. Smart contracts have allowed for the genesis of blockchain-based financial
9 infrastructure, known as DeFi. DeFi generally refers to an open, permissionless, and highly
10 interoperable protocol stack built on public smart contract platforms. DeFi does not rely on
11 intermediaries and centralized institutions, but rather on open protocols and DApps.

12 23. DeFi uses a multi-layered architecture. To conceptualize:

13 a. The *settlement layer* (Layer 1) consists of the blockchain and its native
14 protocol asset (*i.e.* \$ETH (Ether) on the Ethereum blockchain). It allows the network
15 to store ownership information securely and ensures that any state changes adhere to
16 its ruleset. The blockchain can be seen as the foundation for trustless execution and
17 serves a settlement and dispute resolution layer.

18 b. The *asset layer* (Layer 2) consists of all assets that are issued on top of the
19 settlement layer. This includes the native protocol asset as well as any additional assets
20 that are issued on this blockchain (often referred to colloquially as tokens).

21 c. The *protocol layer* (Layer 3) provides standards for specific use cases
22 such as DEXs, debt markets, derivatives, and on-chain asset management. These
23 standards are usually implemented as a set of smart contracts and can be accessed by
24 any user. As such, these protocols are highly interoperable.

25 d. The *application layer* (Layer 4) creates user-oriented applications that
26 connect to individual protocols. The smart contract interaction is usually abstracted by
27 a web browser-based front end, making the protocols easier to use.
28

e. The *aggregation layer* (Layer 5) is an extension of the application layer. Aggregators create user-centric platforms that connect to several applications and protocols. They usually provide tools to compare and rate services, allow users to perform otherwise complex tasks by connecting to several protocols simultaneously, and combine relevant information in a clear and concise manner.

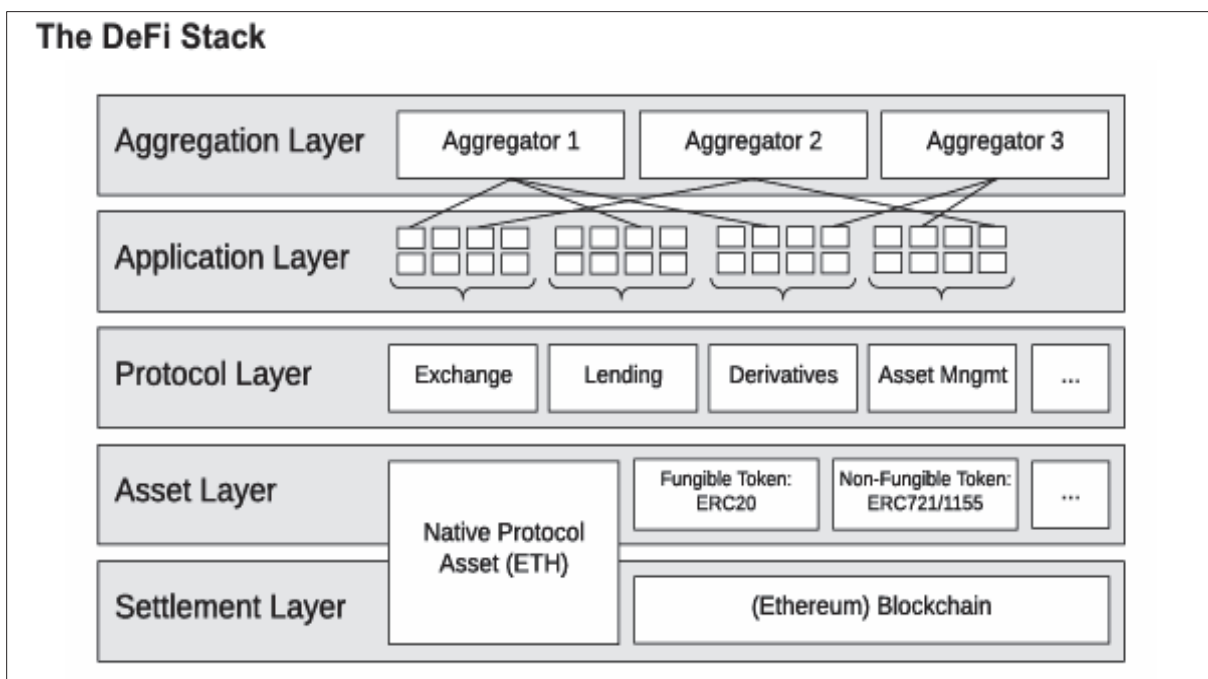

24. Integral to DeFi are DEXs, which exist as a set of persistent, non-upgradable smart contracts, *i.e.*, no single entity controls the codebase. So long as the underlying blockchain on which it operates is functional, a DEX will continue to run as coded. DeFi participants use DEXs for two main reasons:

a. *Providing Liquidity.* Liquidity refers to how much of an asset is available to trade. DEXs rely on third parties to supply liquidity. The liquidity providers (“LPs”) are users who deposit crypto assets into a “liquidity pool” to provide liquidity for a particular token pair that “swappers” can trade with. In return for providing liquidity, LPs earn trading fees generated by that pool.

b. *Swapping.* Unlike traditional centralized cryptocurrency exchanges (or CEXs), DEXs are unique because they allow users to “swap” tokens without third parties facilitating the transaction or taking control of funds. Essentially, users will

1 send their token to the relevant liquidity pool and receive the equal value of the other
2 paired token in return.

3 Criteria	4 Centralized Exchanges	5 Decentralized Exchanges
6  Decentralization	7 Operated by centralized organizations.	8 Operated by users and liquidity providers.
9  Custody of assets	10 The centralized exchange controls access to crypto assets.	11 Users have exclusive control over their assets.
12  Impermanent loss	13 No concerns of impermanent loss due to high liquidity.	14 Impermanent loss is a highly possible risk in event of market fluctuations.
15  Regulations	16 Highly regulated	17 No KYC and AML standards
18  Liquidity	19 Institutional investors and a large user base ensure higher liquidity.	20 Lack of regulatory standards and competition from CEXs reduce liquidity.
21  Trading Options	22 Multiple trading options, including spot trading, futures trading, and others.	23 Only limited to crypto lending and borrowing and speculative investments.
24  Availability	25 Depends on the centralized company operating the exchange.	26 Always accessible to users.

27 *The Ethereum Blockchain and Ecosystem*

28 25. The Ethereum blockchain and its greater ecosystem were first conceived in 2013 by programmer Vitalik Buterin. Beginning at first as a “Proof of Work” digital ledger, in September 2022 Ethereum successfully transitioned into a “Proof of Stake” digital ledger, in part due to the increased activity on its network, which made scaling a priority for developers. Ethereum’s architecture is designed to facilitate the implementation of smart contracts and DApps as well as support a wide range of DeFi platforms and protocols.

26 26. The Native Protocol Asset behind the Ethereum blockchain is Ether, whose cashtag is \$ETH. \$ETH serves as the means of transferring value and securing Ethereum through staking (*i.e.* as a block reward to successful validators).

1 27. Users can create tokens on the Ethereum blockchain via ERC-20, is a technical
2 standard that defines a set of rules and functions that an Ethereum-based ERC-20 token must
3 follow to be compatible with the Ethereum ecosystem. Some key features of ERC-20 are: (i)
4 Token Creation, which allows developers to create new tokens with custom specifications,
5 such as supply, decimals, and other attributes; (ii) Token Management, which provides
6 functionalities for minting and burning;⁵ and (iii) Token Transfers, which enables secure and
7 efficient transfer of tokens between accounts. These ERC-20 tokens are the *asset layer* of the
8 DeFi stack on Ethereum referenced above.

9 28. A number of DEXs operate on the Ethereum blockchain, including but not
10 limited to Uniswap, PancakeSwap, and SushiSwap. These DEXs reside on the *protocol layer*
11 of Ethereum referenced above. These DEXs allow for ERC-20 tokens established via the
12 ERC-20 standard to be traded by investors.

13 ***The Solana Blockchain and Ecosystem***

14 29. The Solana blockchain and its greater ecosystem were created in 2017 by former
15 Qualcomm executive Anatoly Yakovenko. Solana is a hybrid “Proof of Stake” open-source
16 distributed ledger, which has the primary objective of significantly enhancing the scalability
17 of blockchain technology. Its architecture is designed to facilitate the creation of smart
18 contracts and DApps, and it supports a wide range of DeFi platforms and protocols.

19 30. The Native Protocol Asset behind the Solana blockchain is Solana, whose
20 cashtag is \$SOL. \$SOL serves as the means of transferring value and securing Solana through
21 staking (*i.e.* as a block reward to successful validators).

22 31. Users can create tokens on the Solana blockchain via the Solana Primary Library
23 (“SPL”), which defines how smart contract tokens on the Solana blockchain operate. The
24

25 ⁵ “Minting” refers to creating new tokens or coins. “Burning” refers to sending tokens or
26 coins to a special address on the blockchain (“burn address”) where they are no longer able
27 to be accessed or used, and thus effectively destroyed. Burning takes tokens or coins out of
28 circulation, lowering the outstanding supply and theoretically causing the value of remaining
“unburned” tokens or coins to increase due to scarcity principles of economics.

operational standards are delineated in the library and must be adhered to by any token created on the Solana blockchain. These SPL tokens are the *asset layer* of the DeFi stack referenced above.

32. The SPL Token Program, similar to ERC-20 on Ethereum, is a smart contract program within the SPL that enables the creation, management, and transfer of SPL tokens on the Solana blockchain. Some key features of the SPL Token Program include: (i) Token Creation, which allows developers to create new tokens with custom specifications, such as supply, decimals, and other attributes; (ii) Token Management, which provides functionalities for minting and burning; and (iii) Token Transfers, which enables secure and efficient transfer of tokens between accounts.

33. A number of DEXs operate on the Solana blockchain, including but not limited to Raydium, Jupiter, and Orca. These DEXs reside on the *protocol layer* of the DeFi stack on Solana referenced above. These DEXs allow for SPL tokens established via the SPL Token Program to be traded by investors.

Origin of Memecoins

34. Memecoins have existed within cryptocurrency since the creation of Dogecoin in December of 2013.

35. Created by its developers to poke fun at Bitcoin – the first cryptocurrency and first legitimate use case of blockchain technology in general – Dogecoin was branded around a popular internet meme at the time: the “doge” Shiba Inu.



1 36. The founders of the project stated that they chose the name “Dogecoin” to ensure
2 the digital asset was a “joke currency” and “as ridiculous as possible.”

3 37. Starting around 2019, what had begun as a joke transformed into an
4 unprecedented financial phenomenon, due in no short part to celebrity and high-profile public
5 figure endorsement and solicitation of Dogecoin on social media platforms.

6 38. Most notably, Elon Musk began using his Twitter account to endorse and
7 otherwise promote Dogecoin to the public. Over the course of a few years, Musk endorsed
8 Dogecoin several times, directly resulting in drastic price fluctuations. For example:

9 a. On July 17, 2020, Musk tweeted a meme of an arial photo of a dust storm
10 overtaking an urban area, with the face of the Dogecoin Shiba Inu superimposed on the
11 dust cloud, which was labeled “dogecoin standard,” while the urban area about to be
12 overtaken by the dust cloud was labeled “global financial system.” Above this image,
13 Musk wrote, “It’s inevitable.” Immediately following this tweet, Dogecoin’s price rose
14 roughly 14% in less than two hours.

15 b. On December 20, 2020, Musk tweeted, “One word: Doge,” causing the
16 price of Dogecoin to increase by roughly 20% that day.

17 c. On February 10, 2021, Musk tweeted that he had purchased Dogecoin for
18 his son, increasing its price roughly 16% in about 20 minutes.

19 d. On April 15, 2021, Musk tweeted a Dogecoin meme that increased
20 Dogecoin’s trading price more than 358% in 2 days.

21 e. On May 8, 2021, Musk made a highly-anticipated appearance on Saturday
22 Night Live, where it was expected he might again promote Dogecoin. At this time,
23 Dogecoin had reached an all-time high market capitalization of \$95 billion, and all-
24 time peak trading price of \$0.738, an increase of over 36,000% since Musk first
25 endorsed it in April 2019.

26 39. During his SNL appearance, however, Musk said Dogecoin was “a hustle.”
27 Within 15 minutes, Dogecoin’s price had dropped to \$0.54 (a more than 26% drop). It lost
28 \$20 billion in market capitalization before the SNL episode even finished. Within two days,

1 Dogecoin’s market capitalization dropped to \$45 billion and its price to \$0.37 – a nearly 50%
2 decrease from its peak. Dogecoin’s price continued dropping until it sank to \$0.06, a 90%
3 loss, within a year.

4 40. Dogecoin’s history illustrates the extreme volatility in price and market
5 capitalization that can occur to memecoins, due to high-profile figures’ endorsement and
6 promotion, as well as the ability of the market to be influenced by messages or comments
7 directed to these promoters’ followers on social media platforms.

8 *Memecoins Today*

9 41. Despite the volatility – or perhaps because of it – interest in memecoins has
10 exploded since the Dogecoin phenomenon. Memecoins have become popular for many
11 reasons: (i) they offer a low barrier of entry for new investors, as they are cheap, easy to buy,
12 and have high potential for returns; (ii) they appeal to the emotions and humor of the general
13 crypto community, which enjoy the memes, jokes, and social buzz surrounding memecoins;
14 and (iii) they benefit from the network effect and the bandwagon effect – as more people join,
15 the increased hype drives up a memecoin’s demand and price.

16 42. *Millions* of memecoins have emerged since the Dogecoin boom and bust of
17 2019-2021, many trying to replicate Dogecoin’s formula, or to create their own niche. Some
18 were based on other animal memes, like Shiba Inu (a Dogecoin clone), Dogelon Mars (a
19 parody of Elon Musk’s Space X project), Samoyedcoin (a dog breed), and Floki Inu (Musk’s
20 actual pet dog). Others were based on pop culture references, like Pepe (a frog character),
21 HarryPotterObamaSonic10Inu (a mashup of fictional characters), and MonaCoin (a Japanese
22 anime character).

23 43. In the vast majority of cases, the creators of a memecoin are anonymous, which
24 naturally leads to a plethora of scams, rug pulls, and fraud. Nonetheless, the current memecoin
25 market across all blockchains has a total capitalization of roughly \$70 billion dollars,
26 representing an over 200% year-over-year increase since the previous year.⁶

27 _____
28 ⁶ See <https://www.coingecko.com/en/categories/meme-token> (accessed October 29, 2024).

1 44. Solana-based memecoins have particularly become increasingly common, due
2 to the relatively inexpensive transaction fees for investors when buying and selling
3 cryptocurrencies on Solana-based DEXs. With such a parabolic rise in interest in Solana-
4 based memecoins, applications were developed on the network as a response to user demand.

5 45. Most notably, Pump.Fun is a Solana-based interface that allows anyone to create
6 a memecoin nearly instantaneously, for free.⁷

7 46. Pump.Fun is not a DApp or a DEX. Instead, it is a centralized application
8 controlled by a group of individuals located outside of the United States. Pump.Fun works by
9 interacting on a user's behalf with the SPL Token Program to allow the user to mint a new
10 SPL token via prebuilt smart contracts. Users simply insert a name, image, and description
11 of their memecoin to kickstart the fundraising phase. Essentially, this allows anyone to create
12 a memecoin without needing any technical know-how. Pump.Fun collects a fee on these
13 transactions, facilitating token sales while generating revenue.

14 47. Unlike traditional static pricing common in other traditional token sales,
15 Pump.Fun employs a "Bonding Curve" pricing model in which token prices increase with
16 fundraising progress and decrease as tokens are sold. Once the fundraising achieves a certain
17 market value, Pump.Fun adds liquidity to a pool on Raydium (a leading DEX on Solana) and
18 the memecoin then exists and can be traded within the larger Solana ecosystem.

19 48. Despite its popularity and innovative approach, Pump.Fun is inherently risky.
20 The platform's accessibility has led to an oversaturation of memecoins, the majority of which
21 lack true value or utility. Especially in the absence of better information, investors often rely
22 on social cues, such as endorsements from well-known figures, to assess potential projects.

23 49. Over one million memecoins have been deployed via Pump.Fun since its
24 creation in January 2024, and 95% are estimated to be scams or rug pulls.⁸ The entire
25
26

27 ⁷ See generally <https://pump.fun/board>.

28 ⁸ See <https://www.coinspeaker.com/pump-fun-50m-revenue>.

1 phenomenon has been described as a “casino.”⁹ Inevitably, investors able to buy memecoins
2 the earliest, at their lowest prices, either during Pump.Fun Bonding Curves or by accessing
3 memecoins via the Raydium liquidity pool early on, have the greatest chance of seeing the
4 largest rise in price should the memecoins they purchase go “viral.” This tends to result in
5 popular tokens “pumping” when initial interest is high, providing the greatest chance of
6 seeing high returns, and then “dumping” after the initial interest subsides and investors
7 quickly move on to the next “opportunity.”

8 50. In around May 2024, numerous high-profile celebrities, including Jenner, began
9 using Pump.Fun to launch memecoins on the Solana blockchain associated with their
10 particular brand of stardom. Because of the celebrities’ large social media presences, these
11 memecoins were able to attract a significant amount of attention from the public, resulting in
12 the typical “casino” situation, but on a much larger scale. This is especially true because, due
13 to their celebrity creators, the public mistakenly believed these projects had a certain
14 legitimacy that most coins created by anonymous token developers lacked.

15 51. As a result of the growing popularity of memecoin investment, particularly in
16 light of increasing celebrity involvement in the craze, on May 29, 2024, the SEC’s Office of
17 Investor Education and Advocacy released an Investor Bulletin stating:

18 Fraudsters may conduct pump-and-dump schemes with crypto assets, including
19 so-called “memecoins” that refer to popular culture or internet memes. For
20 example, fraudsters may create a memecoin and then tout it on social media –
21 sometimes in what they refer to as a “pre-sale” – to get others to buy and “pump”
22 up, or increase, its price. Then the promoters or others working with them
23 “dump,” or sell, before the hype ends, profiting from the pumped up price.
24 Typically, after the promoters sell and take their profit, the price decreases
25 rapidly, and everyone else who bought the token loses most of their money.
26 ***Never make investment decisions based solely on information from social
27 media platforms or apps.***

28 ⁹ See <https://cointelegraph.com/news/solana-memecoin-crypto-utility-reputation>.

1 ***The First \$JENNER Launch (on Solana)***

2 52. Two days before the SEC’s bulletin was published, on May 26, 2024, Jenner
3 minted \$JENNER on the Solana blockchain using Pump.Fun.¹⁰ On her public Twitter account
4 (@Caitlyn_Jenner), which has over 3 million followers, Jenner posted a link to Pump.Fun,
5 where investors could immediately purchase \$JENNER from the Bonding Curve.



6
7
8
9
10 53. From the very outset, Jenner began promoting this memecoin as legitimate,
11 created by Jenner herself, poised to be successful, and destined to increase in value as Jenner
12 promised to dedicate her full efforts to the project.



13
14
15
16
17 54. Shortly after the mint – and after insiders had time to accumulate \$JENNER
18 before the public was informed by Jenner’s tweet – Hutchins appeared in a separate video
19 post on Twitter (*i.e.*, on Twitter “Spaces”) affirming that \$JENNER was in fact real, and that
20 she was “managing the crypto project.”¹¹

21 ///
22 ///
23 ///
24 ///

25 _____
26 ¹⁰ The public blockchain contract address of \$JENNER on Solana is <https://solscan.io/token/4GJ3TCt5mTgQT5BRKb14AkjddpFQqKVfphxzS3t4foZ9>.

27 ¹¹ See [https://www.coindesk.com/markets/2024/05/27/caitlyn-jenner-meme-coin-sows-](https://www.coindesk.com/markets/2024/05/27/caitlyn-jenner-meme-coin-sows-confusion-as-observers-question-its-provenance)
28 [confusion-as-observers-question-its-provenance](https://www.coindesk.com/markets/2024/05/27/caitlyn-jenner-meme-coin-sows-confusion-as-observers-question-its-provenance).

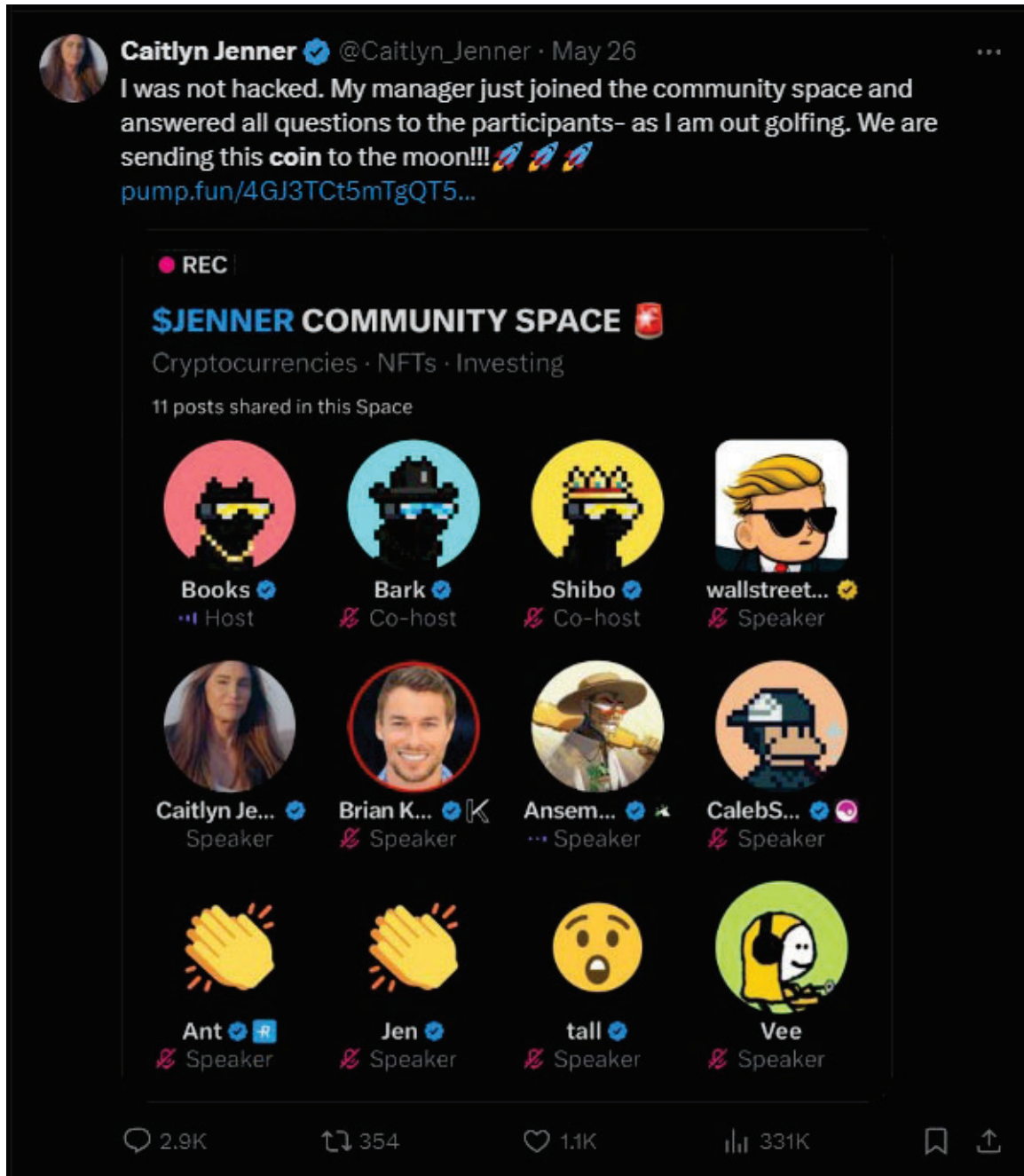

55. Due to Jenner’s stature as an internationally-recognized public figure, and her own initial promotional efforts on social media, \$JENNER almost immediately surpassed the trading threshold on the Pump.Fun Bonding Curve, so it was then available to be traded on Raydium (and, theoretically, all other DEXs existing within the wider Solana ecosystem as well). Not only did Jenner immediately begin touting price and market capitalization targets on the memecoin, astonishingly, \$JENNER amassed over \$250 million in trading volume via more than 300,000 transactions, ultimately leading to a \$43 million market capitalization

1 value distributed between the approximately 20,000 investors who purchased \$JENNER its
 2 first day.



24 56. However, this initial success was short-lived. Confusion and controversy
 25 quickly mounted as social media users began labeling Jenner a grifter because of her
 26 simultaneous promotion of another cryptocurrency project, \$BBARK, depicted in the since-
 27 deleted tweet, below, which appeared based on her and Hutchins' dogs, perhaps meaning to
 28 play off the original memecoin, Dogecoin.

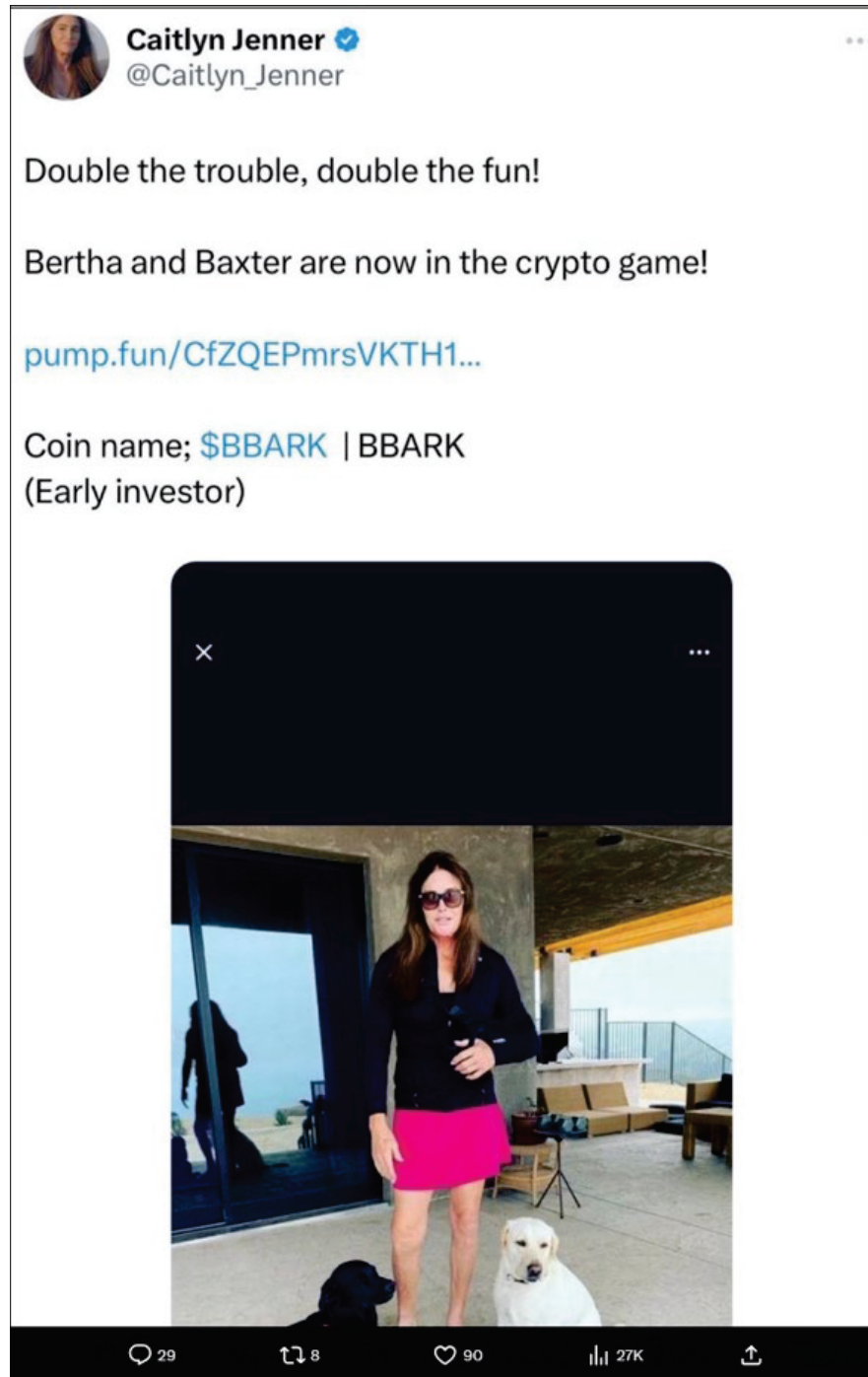

57. As this criticism increased, Jenner posted a series of messages representing that \$BBARK¹² was not her personal memecoin, but rather, she was simply “a great fit for the token” and when “approached to invest in this token meme I was all in!”

¹² \$BBARK is down 99% since its all-time high, which occurred the day of Jenner’s promotion.



58. Jenner’s promotion of \$BBARK coincided with a plateau and drop in the price of \$JENNER, as investors were confused about which project Jenner was truly dedicated to. Jenner assured investors not to worry, saying she was “fully focused on my token \$JENNER.”



1 59. The downfall of the Solana-based \$JENNER coin began when it was revealed
2 that Hutchins and Jenner had initially solicited the help of Sahil Arora, a controversial figure
3 within the cryptocurrency industry, to assist in minting \$JENNER.

4 60. Arora has been accused of orchestrating cryptocurrency scams in the past.¹³
5 Nevertheless, the well-connected influencer has been involved in multiple celebrity-backed
6 cryptocurrency projects and when speaking on the value that celebrities bring to
7 cryptocurrency, has said that generating celebrity memecoin projects is “the only way to make
8 crypto more mainstream and benefit from the attention economy”¹⁴

9 61. Hutchins and Arora had a pre-existing relationship, and Hutchins was
10 responsible for introducing Arora to Jenner to create the \$JENNER project. Jenner and
11 Hutchins used Arora to create \$JENNER, intending to enrich themselves, and – according to
12 a “Non-Binding Term Sheet for Promotional Activity Agreement” they signed with Arora –
13 to “generate maximum revenue for [Jenner] within a timeline of 24 hours from the [initial]
14 tweet from [Jenner]” announcing the project.

15 62. Arora and Jenner subsequently had a falling out. Arora launched the token on
16 behalf of Jenner, had Jenner promote it, and then “dumped” his portion of \$JENNER on the
17 liquidity pool in Raydium or another platform, receiving \$SOL in return, and sending the
18 market price crashing – the exact risk that Jenner had a duty to warn investors of when she
19 was soliciting their purchases, which she willfully failed to do for her own financial benefit.

20 ///

21 ///

22 ///

23 ///

26 ¹³ See <https://cointelegraph.com/news/sahil-arora-banned-celebrity-memecoin-scams>.

27 ¹⁴ See [https://decrypt.co/232565/crypto-promoter-who-launched-caitlyn-jenner-solana-](https://decrypt.co/232565/crypto-promoter-who-launched-caitlyn-jenner-solana-meme-coin)
28 meme-coin.



63. Due to Jenner calling her own project and memecoin a “scam[],” \$JENNER’s market capitalization rapidly plunged to \$5 million as confusion ensued and Jenner issued no concrete explanation. Investor holdings began losing the majority of their value very rapidly.

64. Despite this, Jenner continued to promote the memecoin and assured the public Arora was no longer involved. She promised investors all was well, and that the \$JENNER “will do better now,” despite having just witnessed the token drop over 80% in mere hours. Jenner promised investors that there would be no relaunch, and that this token on the Solana blockchain would continue to grow and be supported by Jenner and her team.





The Second \$JENNER Launch (on Ethereum)

65. Despite her promises to investors and her heavy promotion over the following days, it was evident that the volatility caused by Arora, and the blatant instances of “pump and dumps” that had already occurred, had rocked the community’s trust of \$JENNER on Solana. But Jenner had a strong financial interest in continuing to promote the memecoin.



1 66. However, Jenner also needed a cryptocurrency over which she had full control,
 2 and from which she was guaranteed to profit. Jenner therefore minted another memecoin,
 3 with a distinct contract address but same cashtag and name – \$JENNER – this time on the
 4 Ethereum blockchain, as an ERC-20 token.¹⁵ She then immediately went to social media to
 5 promote it as an investment opportunity: as an ERC-20 token, the new \$JENNER coin was
 6 immediately available for trading on the DEX Uniswap.



22 67. Naturally, due to the confusion and now-competing memecoin on the Ethereum
 23 blockchain, the price of the Solana-based \$JENNER began dropping despite Jenner, for a
 24 couple of days, continuing to promote it, as well, since she had accumulated her own Solana-
 25 based \$JENNER and was still hoping this token would increase in price.

26

27

28 ¹⁵ The public blockchain contract address of \$JENNER on Ethereum is <https://etherscan.io/token/0x482702745260ffd69fc19943f70cffe2cacd70e9>.



6 68. However, Jenner’s dual promotion quickly ended, and she shortly began to
7 condemn \$JENNER on Solana while fully promoting her newly minted \$JENNER on
8 Ethereum.



14 69. Jenner and Hutchens created a separate public social media account for the
15 Ethereum-based \$JENNER token, which has routinely been used for its promotion, as well
16 as a website for the token, jennercoineth.com, which later was taken down either after or
17 during the collapse of the project.

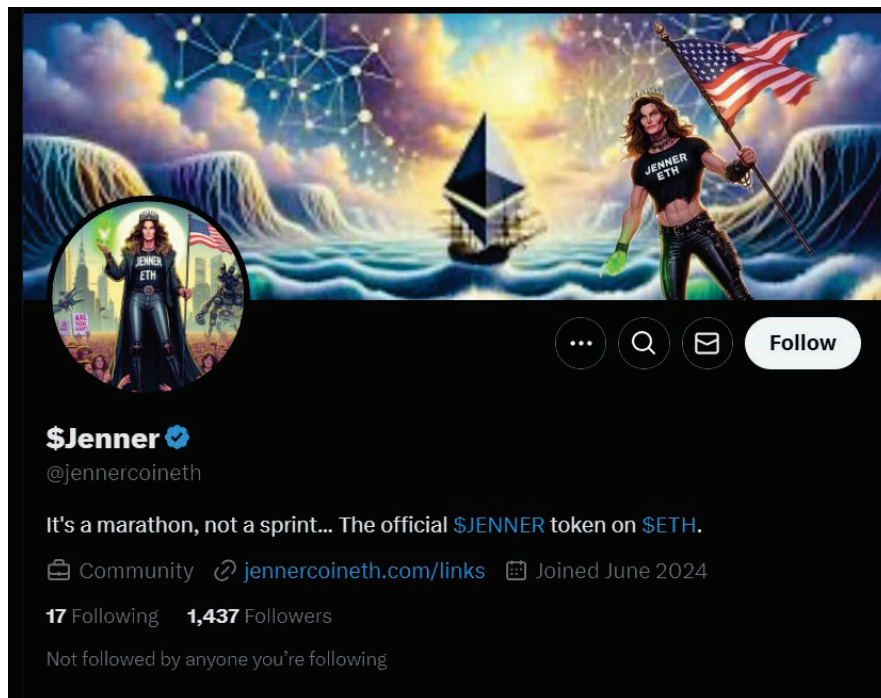

1 70. Unlike the original \$JENNER token, Jenner and her team instituted a 3% “tax”
2 on every Ethereum-based \$JENNER transaction. Thus, for every purchase and sale of
3 \$JENNER on Ethereum, Jenner receives 3% of the total amount traded directly via the smart
4 contract functionality on the Ethereum blockchain.¹⁶

5 71. This element of Ethereum-based \$JENNER has enriched Jenner tremendously,
6 as there have been millions of dollars of transaction volume. Jenner has never properly
7 disclosed this information to investors, and many have paid this transaction tax unknowingly.

8 72. Following the creation of \$JENNER on Ethereum, Jenner now had and has
9 direct control over her own memecoin, from which she is guaranteed to benefit financially,
10 regardless of its underlying price. Jenner was likely able to profit over \$500,000 via this
11 mechanism alone. Much of the cryptocurrency she received as “taxes” was subsequently
12 transferred into the centralized exchange, Coinbase.

13 ***\$JENNER (on both blockchains) is a Security***

14 73. \$JENNER is a security because it constitutes an investment of money in a
15 common enterprise with the reasonable expectation of profit to be derived from the efforts of
16 others. *See SEC v. W.J. Howey Co.*, 328 U.S. 293 (1946).

17 74. On April 3, 2019, the SEC published its “Framework for ‘Investment Contract’
18 Analysis of Digital Assets” (the “Framework”), in which it “provided guidance for analyzing
19 whether a digital asset is an investment contract and whether offers and sales of a digital asset
20 are securities transactions.”¹⁷

21 75. Using the Framework’s guidance, \$JENNER and the manner in which it was
22 offered and sold constitutes an investment contract, and therefore a security, under federal
23 law.

24
25
26 ¹⁶ See <https://dexscreener.com/ethereum/0x8588f0c49849c011d5b5e3318bb0d1fb8534266b>.

27 ¹⁷ See U.S. Securities and Exchange Commission, Framework for “Investment Contract”
28 Analysis of Digital Assets (Apr. 3, 2019), at <https://www.sec.gov/corpfin/framework-investment-contract-analysis-digital-assets>.

1 76. In the Framework, the SEC cautions potential issuers, “If you are considering .
2 . . . engaging in the offer, sale, or distribution of a digital asset, you need to consider whether
3 the U.S. federal securities laws apply.” The SEC explained the basics of the *Howey* test:

4 The U.S. Supreme Court’s *Howey* case and subsequent case law have found that
5 an “investment contract” exists where there is the investment of money in a
6 common enterprise with a reasonable expectation of profits to be derived from
7 the efforts of others. The so-called “*Howey* test” applies to any contract, scheme,
8 or transaction, regardless of whether it has any of the characteristics of typical
9 securities. The focus of the *Howey* analysis is not only on the form and terms of
10 the instrument itself (in this case, the digital asset) but also on the circumstances
11 surrounding the digital asset and the manner in which it is offered, sold, or resold
12 (which includes secondary market sales). Therefore, issuers and other persons
and entities engaged in the marketing, offer, sale, resale, or distribution of any
digital asset will need to analyze the relevant transactions to determine if the
federal securities laws apply.

13 77. Investors who bought \$JENNER invested money or other valuable
14 consideration in a common enterprise. Investors had a reasonable expectation of profit based
15 off the managerial, entrepreneurial, and promotional efforts of Jenner and her team, which
16 included the assistance of Hutchins. Accordingly, \$JENNER is a security.

17 **Investment of Money**

18 78. The SEC states in the Framework, “The first prong of the *Howey* test is typically
19 satisfied in an offer and sale of a digital asset because the digital asset is purchased or
20 otherwise acquired in exchange for value, whether in the form of traditional (or fiat) currency,
21 another digital asset, or other type of consideration.”

22 79. Here, investors purchasing \$JENNER, including Plaintiff, made an investment
23 of money or other valuable consideration (in most cases, \$SOL or \$ETH), satisfying the first
24 prong of the *Howey* test.

25 **Common Enterprise**

26 80. A common enterprise exists when there is a direct correlation between the
27 promoter’s success or failure and the investor’s profits or losses. Furthermore, the SEC states
28

1 in the Framework that “In evaluating digital assets, we have found that a ‘common enterprise’
2 typically exists.”

3 81. Investors purchasing \$JENNER, including Plaintiff, expected their profits to be
4 obtained by the success of Jenner’s and Hutchins’s marketing, promotional, managerial, and
5 entrepreneurial efforts, therefore establishing broad vertical commonality and hence a
6 common enterprise.

7 **Expectation of Profits**

8 82. The Framework states, “When assessing whether there is a reasonable
9 expectation of profit derived from the efforts of others, federal courts look to the economic
10 reality of the transaction.” Furthermore, “A purchaser may expect to realize a return through
11 participating in distributions or through other methods of realizing appreciation on the asset,
12 *such as selling at a gain in a secondary market.*” (emphasis added).

13 83. The Framework identifies several “characteristics” to help assess whether the
14 “reasonable expectation of profits” element is met and says, “The more [certain]
15 characteristics are present, the more likely it is there is a reasonable expectation of profit.”
16 Jenner and \$JENNER meet many of these characteristics, including, without limitation, the
17 ones discussed below.

18 (a) *Characteristic 1* - “The digital asset gives the holders rights to share in the
19 enterprise’s income or profits or to realize gains from capital appreciation of the digital
20 asset. The opportunity may result from appreciation in the value of the digital asset that
21 comes, at least in part, from the operation, promotion, improvement, or other positive
22 developments . . . particularly if there is a secondary trading market that enables digital
23 asset holders to resell their digital assets and realize gains.”¹⁸ Since its genesis,
24 \$JENNER, on both blockchains, has been marketed as a way for investors to realize
25 gains from capital appreciation. The ability to profit was the focus of the marketing
26

27 ¹⁸ The language quoted and underlined here and in the subparagraphs below is from the
28 Framework setting forth these characteristics.

1 efforts spearheaded by the \$JENNER “team” – Jenner and Hutchins. Moreover, as
 2 described herein, \$JENNER had a secondary market established on its first day, which
 3 enabled holders to resell their holdings at a profit.

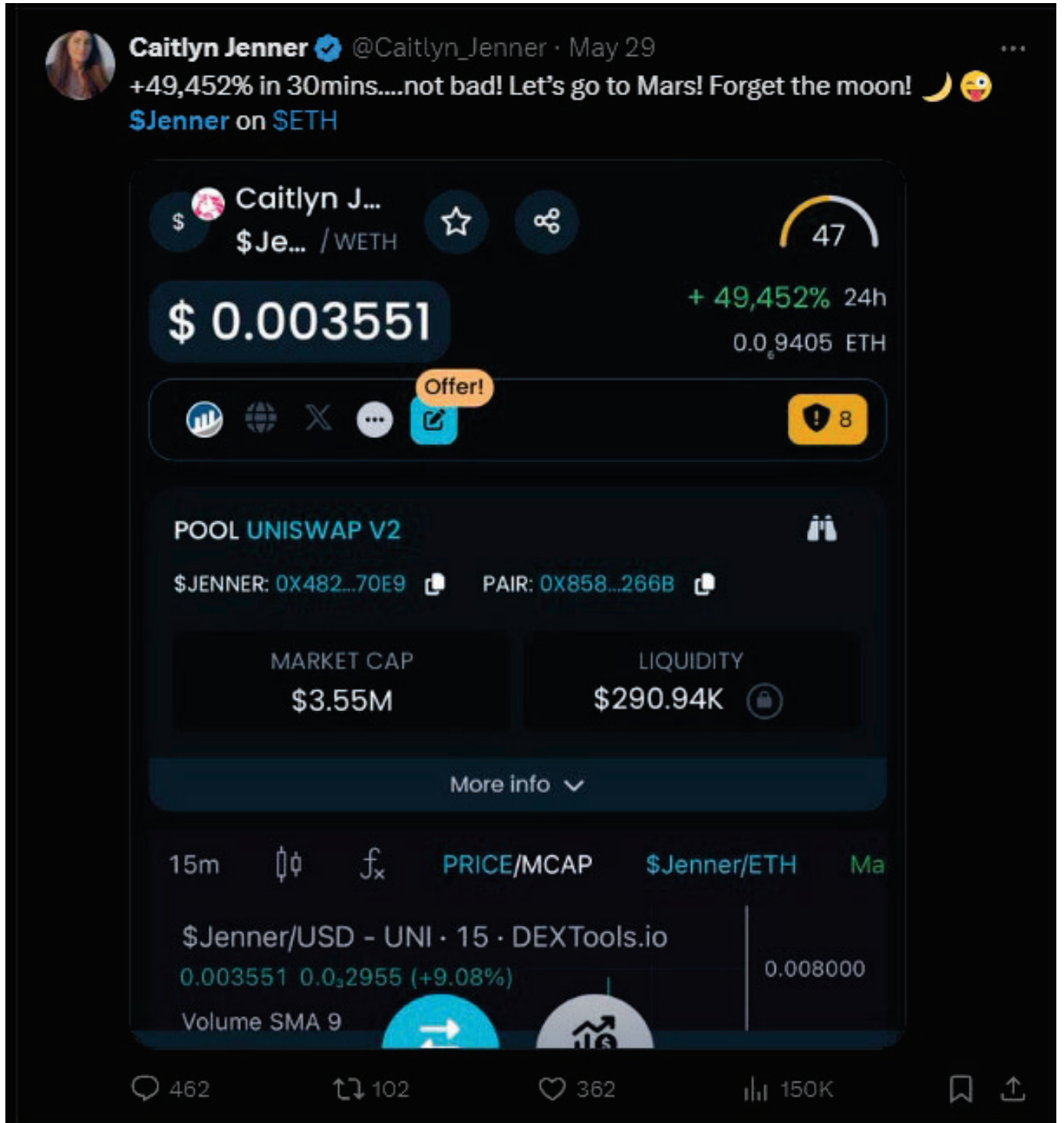



(b) *Characteristic 2* – “The digital asset is transferable or traded on or through a secondary market or platform or is expected to be in the future.” Jenner has facilitated investor access to secondary trading markets on Pump.Fun, various DEXs including Raydium and Uniswap, and has promised to gain listings on a few notable centralized exchanges (CEXs), which never manifested. Plaintiffs and the Class relied on these false and misleading promises by Jenner about CEX listings when they invested in \$JENNER, and when these promises did not manifest, holders had no recourse as the price of \$JENNER had collapsed so much since the start of the enterprise.

1
2
3
4
5
6
7
8
9
10
11
12
13
14
15
16
17
18
19
20
21
22
23
24
25
26
27
28

Caitlyn Jenner @Caitlyn_Jenner · May 28

Of course \$Jenner is a long term project. We are not planning on going anywhere but up and taking \$Jenner everywhere. It's been a couple days and we are very happy with the growth on @pumpdotfun in those couple days. This is just the beginning for us. Now trading on Raydium.

Bastille @BastilleBtc · May 28

\$JENNER price action will be determined on the next Fundamental news announcement from the Jenner Team, as to whether the project will be continued as a long term project. Until then will be bouncing between support at \$20M and the trend line resistance at \$28M.

...
[Show more](#)

236 137 557 72K

Caitlyn Jenner @Caitlyn_Jenner · Jun 27

\$Jenner on \$ETH

Website: jennercoineth.com
TG Group Chat: t.me/JennerCoinPort...
Uniswap Link (to trade): app.uniswap.org/explore/tokens...
X Acct: [@jennercoineth](https://twitter.com/jennercoineth)
ONLY CONTRACT ADDRESS:
0x482702745260Ffd69FC19943f70cFFE2caCd70e9

112 46 236 71K

1 (c) *Characteristic 3* – “Purchasers reasonably would expect that an AP’s efforts
 2 will result in capital appreciation of the digital asset and therefore be able to earn a
 3 return on their purchase.”¹⁹ Jenner has touted on social media on numerous occasions
 4 that the purpose of the project is capital appreciation for investors.



18 (d) *Characteristic 4* – “The AP is able to benefit from its efforts as a result of
 19 holding the same class of digital assets as those being distributed to the public.” Jenner
 20 has, at various times, accumulated significant holdings of both the Solana-based and
 21 Ethereum-based \$JENNER tokens. Jenner intended to accumulate these tokens at low
 22 prices, and to sell at higher prices in the future following an increase in value
 23 surrounding increased speculation in the project. Furthermore, she has received a
 24 significant amount of revenue from the Ethereum-based \$JENNER transaction taxes,
 25 likely over \$500,000.

26

27 ¹⁹ The Framework defines Active Participant, or AP, as a promoter, sponsor, or other third
 28 party (or affiliated group of third parties). As the primary promoter and sponsor of \$JENNER,
 Jenner is an AP.



5 (e) *Characteristic 5* – “The digital asset is marketed, directly or indirectly,
 6 using . . . the [ability of an AP] to build or grow the value of the . . . digital asset.” On
 7 several occasions over the span of multiple months, Jenner promoted the investment
 8 opportunity on social media as one which would be successful due to her own ability
 9 to build or grow the value of \$JENNER. Jenner falsely led investors to believe that the
 10 project was a “marathon not a sprint” and that she would be there for the long term to
 11 build the project.



1
2
3
4
5
6
7
8
9
10
11
12
13
14
15
16
17
18
19
20
21
22
23
24
25
26
27
28

YK
 Forwarded from
 (📎) \$JENNER Coin (ETH)
 Our dev has an ESPY
 Our dev has been on TV for
 50 years - viewed by billions
 of people - literally
 Our dev is a household name
 since he was 27 years old
 Our dev has been Time
 Magazine person of the year
 twice
 Our dev has been on
 countless magazine covers
 like sports illustrated (twice),
 Playgirl, Glamour, People
 Magazine, Forbes, Vanity
 Fair, New York Times, Wall
 Street Journal, the list goes
 on
 Our dev had the longest
 running reality tv show in the
 world
 Our dev has raised the most
 famous family / parent to the
 most famous family in the
 world
 Our dev has raised 3
 billionaire daughters

Our dev is connected to the
 most powerful people in the
 world
 The list goes on and on

 And so many of you guys
 complain non stop, every
 day, about her not being
 active in a TG channel, or
 doing voice chats with y'all.
 And Not updating you on
 things that aren't finalized
 yet.

 You guys have got to get a
 reality check here.

 If you're not bullish on this
 dev - you clearly don't know
 who you're dealing with and
 shouldn't be here in the first
 place and should sell (no
 shame in selling and this is
 not financial advice) because
 you just simply don't get it.

Y Zoom out! 10:50

(f) *Characteristic 6* – “The digital asset is marketed in terms that indicate it is an investment or that the solicited holders are investors.” By promoting \$JENNER as a memecoin which could easily and immediately be traded, and touting its ability to rapidly increase in value, Jenner marketed her memecoin as a “fun” investment to investors, regardless of their financial sophistication.

///
///
///
///

1
2
3
4
5
6
7
8
9
10
11
12
13
14
15
16
17
18
19
20
21
22
23
24
25
26
27
28



1 (g) *Characteristic 7* – “The digital asset is marketed, directly or indirectly,
 2 using the future (and not present) functionality of the . . . digital asset, and the prospect
 3 that an AP will deliver that functionality.” Jenner has leveraged her family’s celebrity
 4 status to imply \$JENNER would have some sort of integrated consumptive or
 5 utilitarian purpose in the future. Jenner has also stated her intentions to make
 6 \$JENNER “the most viral memecoin ever.”

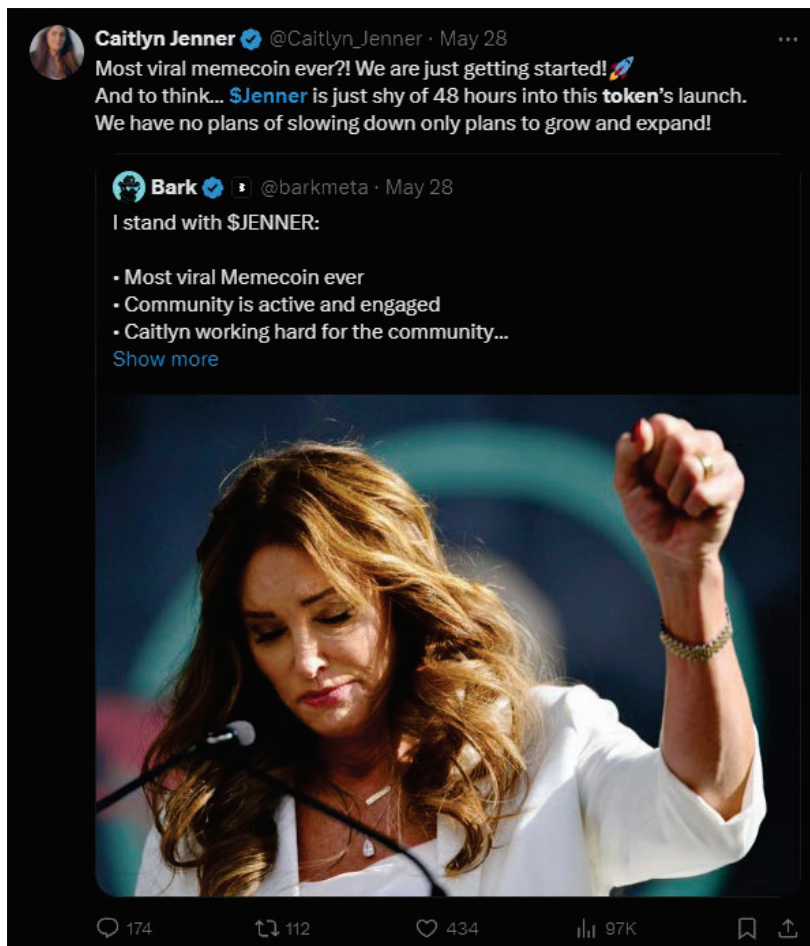

1 (h) *Characteristic 8* – “The potential . . . appreciation in the value of the
2 digital asset, is emphasized in marketing or other promotional materials.” Jenner has
3 continuously and repeatedly emphasized the potential for \$JENNER to increase in
4 value in publicly-facing statements on social media, including illustrative graphics
5 depicting financial and trading advice.

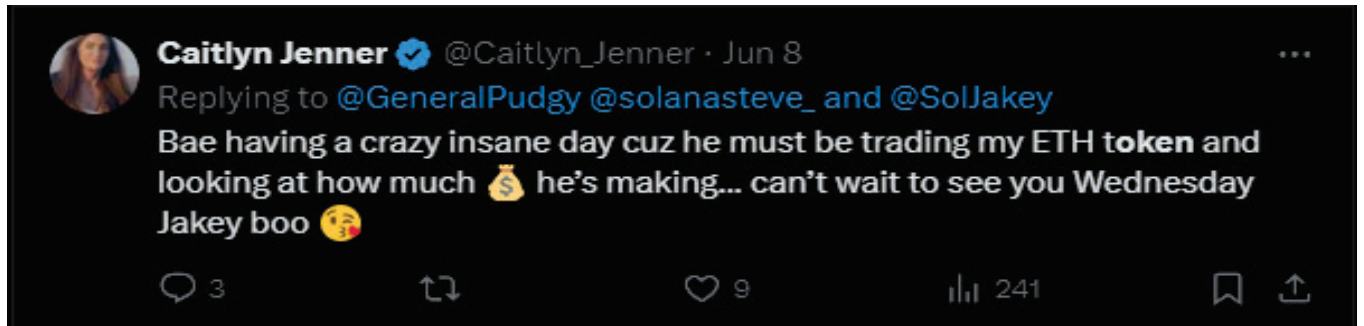

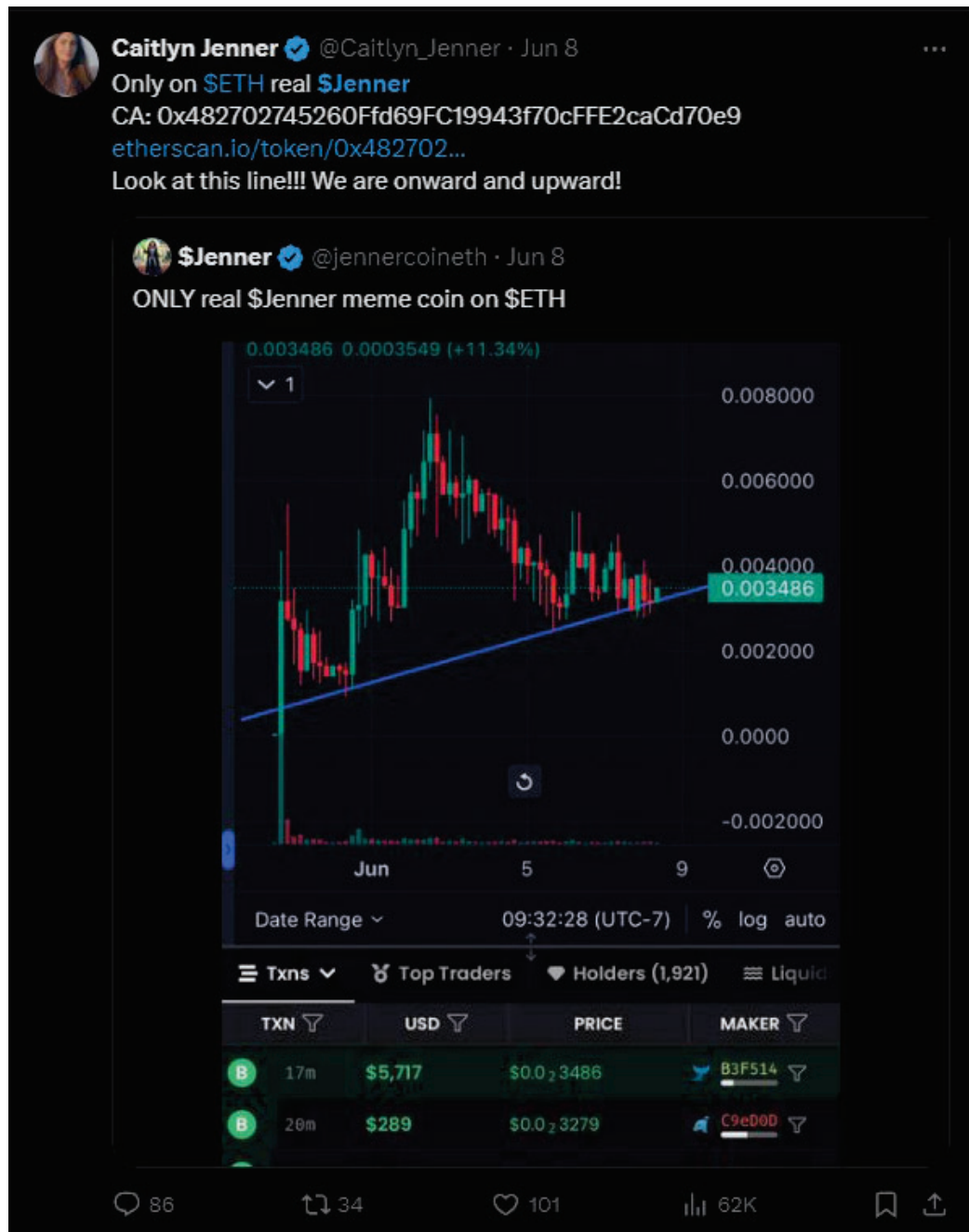

22 (i) *Characteristic 9* – “The availability of a market for the trading of the
23 digital asset, particularly where the AP implicitly or explicitly promises to create or
24 otherwise support a trading market for the digital asset.” Jenner actively and repeatedly
25 told investors she would get the Ethereum-based \$JENNER listed on major CEXs, so
26 as to increase trading volume and liquidity for investors. These promises were the
27 direct and proximate cause of investors choosing to purchase and hold \$JENNER, and
28 when Jenner was not able to successfully get the token listed on multiple reputable

1 U.S.-based CEXs, either willfully or via incompetence, the project was unable to ever
 2 recover, and investors have become unable to recoup their losses. The couple of minor
 3 foreign CEXs on which Jenner was able to get \$JENNER listed have either begun to
 4 or already delisted the token due to lack of trading volume and liquidity following the
 5 collapse of the \$JENNER project. Jenner used the proceeds she received from the offer
 6 and sale of \$JENNER to pay for the listings on the foreign CEXs, likely between
 7 \$10,000 and \$40,000 per listing.



(j) *Characteristic 10* – “The digital asset is offered broadly to potential purchasers as compared to being targeted to expected users of the goods or services or those who have a need for the functionality of the [digital asset].” Since there is no consumptive or utilitarian use case for \$JENNER, and its entire appeal to investors is based off speculation, the memecoin has been offered and sold broadly to the general public without regard for their need or sophistication.



Efforts of Others

84. The Framework provides that the “inquiry into whether a purchaser is relying on the efforts of others focuses on two key issues: Does the purchaser reasonably expect to rely on the efforts of an AP? Are those efforts ‘the undeniably significant ones, those essential managerial efforts which affect the failure or success of the enterprise,’ as opposed to efforts that are more ministerial in nature?”

1 85. The Framework identifies a number of characteristics to help assess whether a
 2 purchaser is relying on the efforts of others and states that, “Although no one of the . . .
 3 characteristics is necessarily determinative, the stronger their presence, the more likely it is
 4 that a purchaser of a digital asset is relying on the ‘efforts of others.’” Jenner and \$JENNER
 5 meet many of these characteristics, including, without limitation, the ones discussed below.

6 (a) *Characteristic 1* – “An AP is responsible for the development, improvement
 7 (or enhancement), operation, or promotion of the [digital asset], particularly if
 8 purchasers of the digital asset expect an AP to be performing or overseeing tasks that
 9 are necessary for the [digital asset] to achieve or retain its intended purpose or
 10 functionality.” Both Jenner and Hutchins have made clear to investors that they are
 11 leading the \$JENNER project and will be performing or overseeing tasks necessary to
 12 facilitate an increase in value for \$JENNER. For example, Hutchins assisted Jenner by
 13 running the project’s public Telegram account and by conducting multiple Twitter
 14 Spaces sessions where she answered investors’ questions. Jenner or Hutchins were
 15 responsible for all business-related dealings with CEXs and market makers as well.





18 (b) *Characteristic 2* – “Where the [digital asset] is still in development and
19 the [digital asset] is not fully functional at the time of the offer or sale, purchasers
20 would reasonably expect an AP to further develop the functionality of the [digital asset]
21 (directly or indirectly). This particularly would be the case where an AP promises
22 further developmental efforts in order for the digital asset to attain or grow in value.”
23 On numerous occasions, Jenner has promised investors she would be involved with
24 developing \$JENNER for the long haul, until the project was successful, since it is her
25 “official memecoin.” But since September 2024, Jenner has stopped posting on social
26 media information directly related to \$JENNER, both the Telegram account and
27 jennercoineth.com have been shut down, and Jenner has all but abandoned the project,
28 leaving holders with essentially worthless cryptocurrency.



1
2
3
4
5
6 (c) *Characteristic 3* – “There are essential tasks or responsibilities performed and expected to be performed by an AP, rather than an unaffiliated, dispersed community of network users (commonly known as a ‘decentralized network’).” There is no decentralized network or “decentralized autonomous organization” (“DAO”) behind \$JENNER, but only Jenner and Hutchins, who are responsible for the memecoin’s development and promotion, including all business, managerial, and entrepreneurial decisions related to the project.



13
14
15
16 (d) *Characteristic 4* – “An AP creates or supports a market for, or the price of, the digital asset. This can include, for example, an AP that (1) controls the creation and issuance of the digital asset; or (2) takes other actions to support a market price of the digital asset, such as by limiting supply or ensuring scarcity, through, for example, buybacks, ‘burning,’ or other activities.” Not only did Jenner initiate the mint and issuance of \$JENNER on both blockchains, but on numerous occasions she has promised investors she would initiate token “buy backs,” thereby artificially inflating the market in an attempt to support the underlying price. A major selling ploy Jenner used on the original Solana-based \$JENNER holders, to get them to purchase her subsequent Ethereum-based \$JENNER (now with a hidden transaction tax), was to promise these buy backs, which were supposed to benefit investors. Jenner never initiated these buy backs in any meaningful way. These false and misleading statements were a direct and proximate cause of the losses suffered by Plaintiffs and the Class.



12 (e) *Characteristic 5* – “An AP has a continuing managerial role in making
13 decisions about or exercising judgment concerning . . . the characteristics or rights the
14 digital asset represents including determining whether and where the digital asset will
15 trade. For example, purchasers may reasonably rely on an AP for liquidity, such as
16 where the AP has arranged, or promised to arrange for, the trading of the digital asset
17 on a secondary market or platform.” Jenner was responsible for providing the initial
18 liquidity for \$JENNER on Ethereum, and has promised to arrange for its trading
19 elsewhere on other secondary markets or platforms.

20 ///
21 ///
22 ///
23 ///
24 ///
25 ///
26 ///
27 ///
28 ///

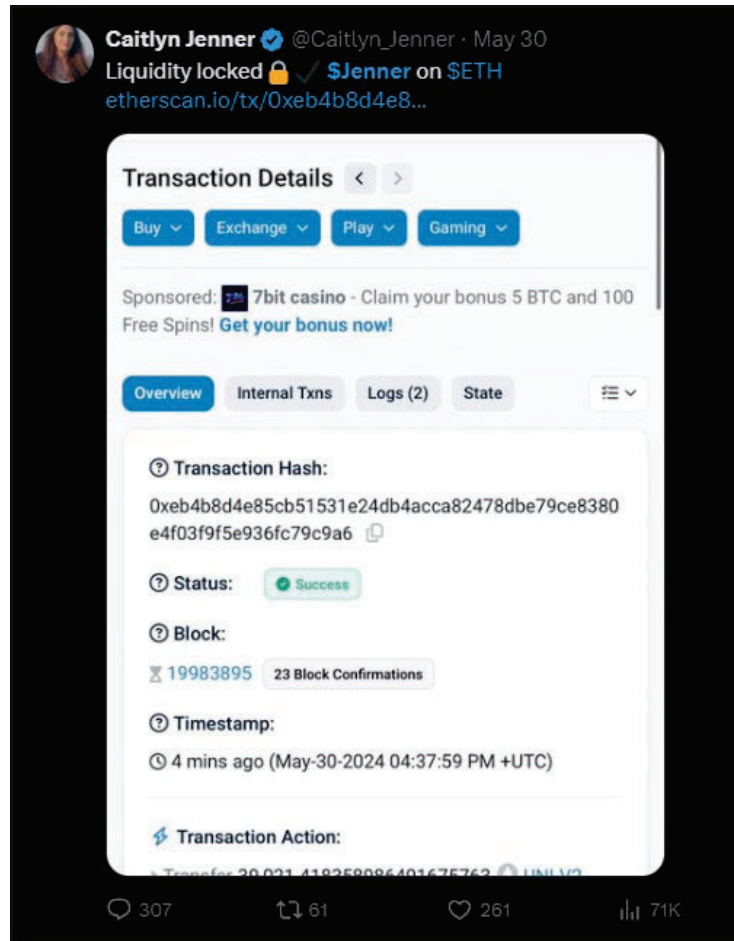

(f) *Characteristic 6* – “An AP [makes] . . . managerial judgments or decisions that will directly or indirectly impact the success of the value of the digital asset generally.” Jenner, with Hutchins’ assistance, is responsible for all managerial judgments or decisions that have any meaningful impact on the success of \$JENNER. These include, *inter alia*, business decisions surrounding CEX listings, promotional and marketing budgeting and activities, and timing of mints. Hutchins had assisted Jenner with running the various social media accounts and websites used to promote \$JENNER.



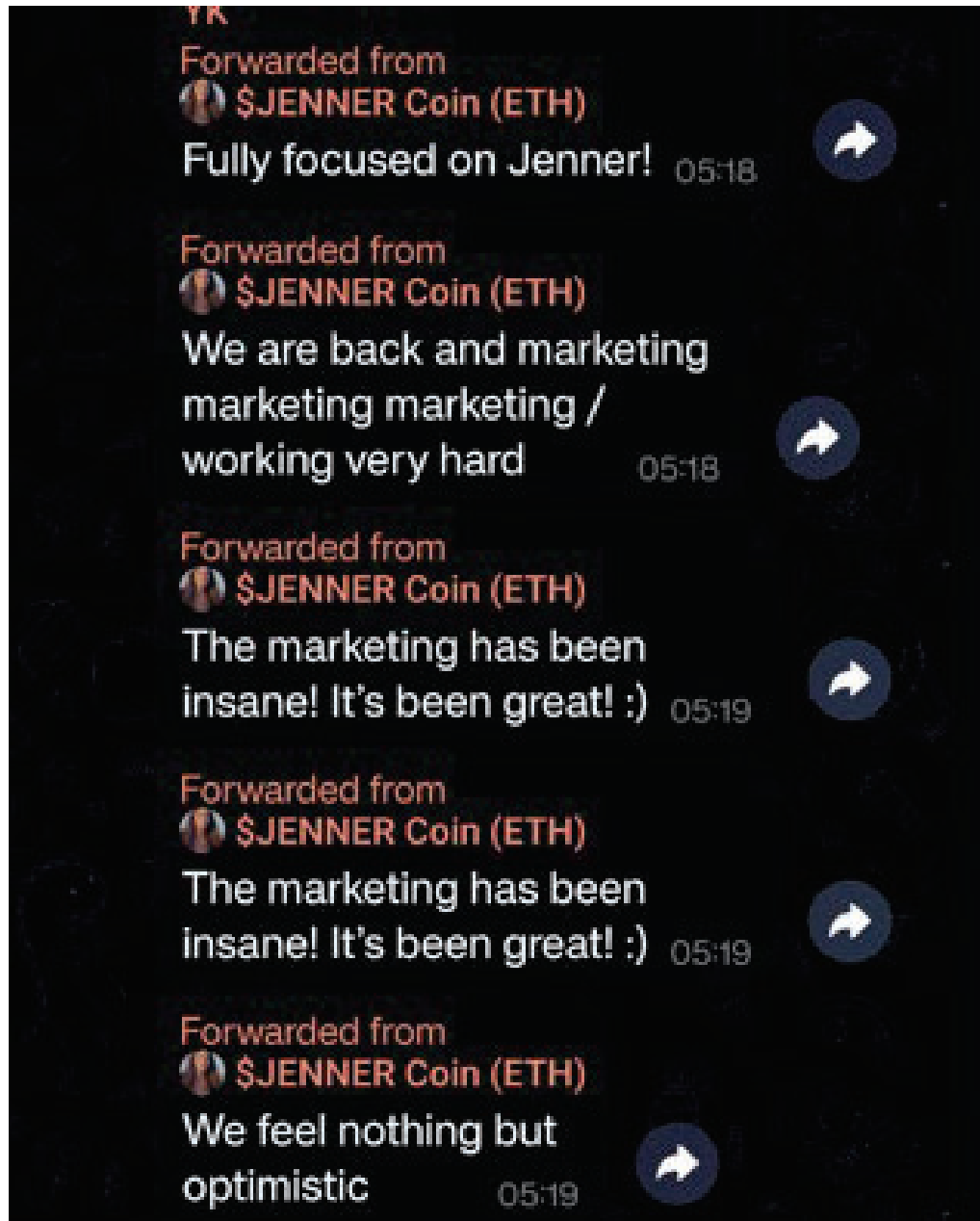

(g) *Characteristic 7* – “Purchasers would reasonably expect the AP to undertake efforts to promote its own interests and enhance the value of the network or digital asset, such as where the AP has the ability to realize capital appreciation from the value of the digital asset. This can be demonstrated, for example, if the AP retains

1 a stake or interest in the digital asset.” Jenner continuously stated she intends to
 2 purchase more of her own memecoin, and not only profits from any underlying
 3 appreciation of the digital asset, but also from the transaction taxes imposed on every
 4 transaction of \$JENNER on the Ethereum blockchain.



5
 6
 7
 8
 9 (h) *Characteristic 8* – “The AP monetizes the value of the digital asset,
 10 especially where the digital asset has limited functionality.” As there is no functionality
 11 to \$JENNER, Jenner continuously solicited investors so to monetize the digital asset
 12 and attempt to drive its underlying value higher.



13
 14
 15
 16
 17
 18
 19
 20
 21
 22 (i) *Characteristic 9* – “An AP has a continuing managerial role in making
 23 decisions about or exercising judgment concerning . . . determining who will receive
 24 additional digital assets and under what conditions.” Jenner has created additional
 25 cryptocurrency projects, including a non-fungible token, with which she has promised
 26 to reward \$JENNER holders in some fashion, granting its holders ownership rights to
 27 her Olympic gold medal. However, this once again did not manifest, and was another
 28 proximate and direct cause leading investors to purchase \$JENNER.

1
2
3
4
5
6
7
8
9
10
11
12
13
14
15
16
17
18
19
20
21
22
23
24
25
26
27
28

Caitlyn Jenner @Caitlyn_Jenner · Aug 5
Replying to @Caitlyn_Jenner
And as posted on @jennercoineth from \$Jenner community TG

\$JENNER Coin (ETH)
Hey all: Lots of Questions regarding how this Fractionalized NFT - backed by RWA- then tokenized - and how it will reward \$Jenner holders. First and foremost, whenever I engage in any activity within Web3 or within the Crypto space, I have a criteria that is very clear: how can I contribute and work to benefit and provide something positive to the Industry, Project(s), and then of course, the Holders. \$JENNER is a separate token and we still have a very active team on \$JENNER and that it is the team's primary focus here. It has been and will remain the primary focus here. We have a very specific answer and plan there that has been in the works alongside this project's development for quite some time - for about 2 months since we finalized. This is set to be implemented / executed as we launch the other project on Thursday. All \$Jenner holders will be rewarded and we look forward to sharing that reward with all \$Jenner holders, Thursday.

1K

\$Jenner and 1976 Olympic Gold Decathlon Medal

15 replies 3 retweets 25 likes 15K views



(j) *Characteristic 10* – “An AP has a continuing managerial role in making decisions about or exercising judgement concerning . . . making or contributing to managerial level business decisions, such as how to deploy funds raised from sales of the digital assets.” In addition to promising to use some of her transaction tax revenue to fund the 2024 presidential campaign of Donald J. Trump, Jenner promised to use some of the funds she has earned from sales of \$JENNER to get the Ethereum-based token listed on prominent CEXs and provide buybacks to holders – both of which never happened and were a proximate and direct cause of losses suffered by Plaintiffs and the Class.



Jenner Issued, Offered, and Sold Unregistered Securities

86. Section 12 of the Securities Act of 1933 states that “[a]ny person who . . . offers or sells a security” in violation of its substantive provisions “shall be liable . . . to the person purchasing such security from him.”

87. This liability attaches to the “owner who passed title, or other interest in the security, to the buyer for value” or a person “*who successfully solicit[ed] the purchase,*

1 *motivated at least in part by a desire to serve his own financial interest or those of the*
2 *securities owner.” Pinter v. Dahl, 486 U.S. at 642, 647 (1988) (emphasis added).*

3 88. Jenner consistently and repeatedly solicited investors, through social media
4 posts, public appearances, and public statements, to purchase \$JENNER, both on Solana and
5 Ethereum, to serve her own financial interests. Not only did Jenner benefit from obtaining
6 \$JENNER earlier and cheaper than the general public (the value of which was poised to
7 increase based on her own efforts to sustain and grow community interest in the project), but
8 she was motivated by a desire to bring attention to her own particular brand of celebrity.
9 Additionally, Jenner specifically stated on numerous occasions that the project’s creation was
10 to benefit her own underlying financial interests, and took concrete steps to achieve that goal
11 by implementing the transaction tax on the Ethereum-based \$JENNER.

12 ***Jenner Omitted or Misrepresented Material Information Related to \$JENNER***

13 89. Jenner omitted or misrepresented material information in connection with her
14 solicitation of investors to purchase \$JENNER.

15 90. Jenner willfully omitted information which would have been deemed by a
16 reasonable investor important to have when buying or selling \$JENNER. Such information
17 includes, *inter alia*: Jenner’s (and other insiders’, such as Hutchins’s) personal holdings of
18 \$JENNER; the public wallet addresses she uses to hold or trade \$JENNER; the price at which
19 she personally has purchased and continued to accumulate \$JENNER during relevant period;
20 the financial risks associated with memecoin investment generally, and her project
21 specifically; details surrounding her involvement with Sahil Arora; and detailed and reliable
22 financial forecasts and analyses of the current and future state of the project.

23 91. Furthermore, Jenner made false statements, some of which were forward
24 looking, which were known to be false or were made with a reckless disregard for their truth.

25 92. For example, Jenner repeatedly touted to investors the ability of \$JENNER to
26 increase continuously and exponentially in value, despite knowing the vast majority of
27 memecoins lose over 90% of their value. Jenner also misled investors to believe there would
28 be multiple listings on reputable CEXs and token buy backs, neither of which manifested.

1 She also suggested \$JENNER would see increased utility, which similarly did not manifest.
2 Jenner constantly downplayed or completely omitted the risks involved in investing in
3 \$JENNER, and instead chose to paint the investment as an effortless, “fun,” no-risk way to
4 make a quick profit. Jenner has promised to create “community” around her online and
5 personal celebrity persona to the benefit of the “early adopters” she has been soliciting
6 without disclosing the risks and possible pitfalls associated with investing in \$JENNER.

7 ***The Class Has Suffered Significant Damages from Defendants’ Actions***

8 93. As a direct result of Jenner’s unlawful and fraudulent creation, solicitation, offer,
9 and sale of unregistered securities with Hutchins’s assistance, Plaintiffs and the Class – many
10 of whom are retail investors and lack the technical and financial sophistication necessary to
11 have evaluated the risks associated with their investments in \$JENNER and were denied the
12 information that would have been contained in the materials required for the registration of
13 \$JENNER – have suffered significant damages. Presently, Jenner appears to have all but
14 abandoned the project, no longer actively promotes the memecoin, and has left holders on the
15 hook for serious losses. It is unlikely these losses can ever be recovered, since \$JENNER, on
16 both Solana and Ethereum, is down 99% from its all-time highs.

17 94. Although the project has failed, trading volume is way down, and Jenner seems
18 to have abandoned the hype, she did post about the project as recently as September of 2024,
19 mocking a person who had lost their life savings investing in \$JENNER, and still declaring,
20 “We aren’t going anywhere.”

21 ///

22 ///

23 ///

24 ///

25 ///

26 ///

27 ///

28 ///



95. Currently, there appears to be a few thousand dollars’ worth of trading volume still occurring daily on the Ethereum-based \$JENNER.²⁰ Unless enjoined, there is nothing preventing Jenner from promoting the project at a later date and repeating this fraudulent behavior.



CLASS ALLEGATIONS

96. While reserving the right to redefine or amend the class definition prior to or as part of a motion seeking class certification, pursuant to Federal Rule of Civil Procedure 23, Plaintiffs seek to represent a “Class” of all persons who purchased \$JENNER between the

²⁰ See <https://etherscan.io/token/0x482702745260ffd69fc19943f70cffe2cacd70e9>.

1 time it was first offered for sale, and the time a Class is notified of certification (the “Class
2 Period”). Excluded from the Class are Defendants, any \$JENNER insider, and any entity in
3 which Defendants have or had a controlling interest.

4 97. The members of the Class are so numerous that joinder of all members is
5 impracticable. As of November of 2024, there are thousands of public digital wallets either
6 previously transacting in, or currently still hold, \$JENNER on both blockchains. Therefore,
7 while the exact number of Class Members is unknown, Plaintiffs believe there are likely
8 thousands of Members of the proposed Class.

9 98. Plaintiffs’ claims are typical of the claims of other Class Members, as all Class
10 Members were similarly affected by Defendants’ wrongful conduct in violation of the laws,
11 as complained of herein.

12 99. Plaintiffs will fairly and adequately protect the interests of the Class and has
13 retained counsel competent and experienced in class action litigation.

14 100. Common questions of law and fact exist as to all members of the Class and
15 predominate over any questions solely affecting individual members of the Class, among
16 them:

17 a. Whether \$JENNER, or the manner in which it was offered and sold,
18 constitute securities under federal law;

19 b. Whether Jenner’s offer and sale of \$JENNER violated the Securities Act;

20 c. Whether Jenner fraudulently misrepresented or omitted material
21 information in connection with the offer and sale of securities;

22 d. Whether Hutchins is liable as a control person of \$JENNER under Section
23 15(a) of the Securities Act;

24 e. Whether Hutchins (a) knew Jenner’s conduct constitutes a breach of duty
25 and gave substantial assistance or encouragement to Jenner to so act, or (b) gave
26 substantial assistance to Jenner in accomplishing a tortious result and Hutchin’s own
27 conduct, separately considered, constitutes a breach to the investors;

28 f. To what extent Plaintiffs and the Class have sustained damages; and

1 g. The proper measure of damages.

2 101. A class action is superior to all other methods of fair and efficient adjudication
3 of this controversy since joinder of all members is impracticable. Furthermore, as the
4 damages suffered by individual Class Members may be relatively small, the expense and
5 burden of individual litigation make it impossible for Class Members to individually redress
6 the wrongs done to them. There will be no difficulty in the management of this action as a
7 class action.

8 **CAUSES OF ACTION**

9 **FIRST CAUSE OF ACTION**

10 **Unregistered Offer and Sale of Securities**

11 **In Violation of Sections 5 and 12(a)(1) of the Securities Act**

12 **(Against Jenner)**

13 102. Plaintiff's realleges and incorporates the allegations elsewhere in the Complaint
14 as if set forth fully herein.

15 103. Section 5(a) of the Securities Act provides:

16 Unless a registration statement is in effect as to a security, it shall be unlawful for
17 any person, directly or indirectly (1) to make use of any means or instruments of
18 transportation or communication in interstate commerce or of the mails to sell
19 such security through the use or medium of any prospectus or otherwise; or (2)
20 to carry or cause to be carried through the mails or in interstate commerce, by
any means or instruments of transportation, any such security for the purpose of
sale or for delivery after sale.

21 15 U.S.C. § 77e(a).

22 104. Section 5(c) of the Securities Act provides:

23 It shall be unlawful for any person, directly or indirectly, to make use of any
24 means or instruments of transportation or communication in interstate commerce
25 or of the mails to offer to sell or offer to buy through the use or medium of any
26 prospectus or otherwise any security, unless a registration statement has been
filed as to such security[.]

27 *Id.* § 77e(c).

28

1 105. Section 12(a)(1) of the Securities Act grants Plaintiffs and the Class a private
2 right of action against any person who offers or sells a security in violation of § 5, and states
3 that such person:

4 Shall be liable . . . to the person purchasing such security from him, who may sue
5 either at law or in equity in any court of competent jurisdiction, to recover
6 consideration for such security with interest thereon, less the amount of any
7 income received thereon, upon the tender of such security, or for damages if he
no longer owns the security.

8 *Id.* § 771(a)(2).

9 106. Jenner is a “seller” and “offeror” within the meaning of the Securities Act
10 because she solicited Plaintiffs and the Class to invest in \$JENNER for her own financial
11 benefit.

12 107. In connection with the sale of unregistered \$JENNER, Jenner unlawfully made
13 use of means or instruments of transportation or communication in interstate commerce or of
14 the mails for the purpose of offering, selling, or delivering unregistered securities in direct
15 violation of §§ 5(a), 5(c), and 12(a)(1) of the Securities Act.

16 108. The sale of \$JENNER constituted sales of unregistered securities under federal
17 law.²¹ \$JENNER and the manner in which it was offered and sold exhibits the following
18 hallmarks of a security under the test articulated in *SEC v. W.J. Howey Co.*, 328 U.S. 293
19 (1946): (a) in order to receive any \$JENNER, an investment of money in the form of a
20 cryptocurrency was required; (b) the investment of money was made into the common
21 enterprise; (c) there was an expectation of returns on the investment; and (d) the potential
22 returns depended on Jenner’s ability to promote \$JENNER and her efforts to grow the project.

23 109. Jenner offered or sold \$JENNER to Plaintiffs and other Class Members.
24 Plaintiffs and other Class Members purchased \$JENNER based on Jenner’s offers and
25 solicitations to buy.

26
27
28 ²¹ See Section 2(a)(1) of the Securities Act, 15 U.S.C. § 77b(a)(1).

1 110. No registration statements have been filed with the SEC or have been in effect
2 with respect to the sale of \$JENNER. The sale of \$JENNER was not a transaction exempt
3 from the registration requirements of the Securities Act. By reason of the foregoing, Jenner
4 has violated §§ 5(a), 5(c), and 12(a)(1) of the Securities Act.

5 111. As a direct and proximate result of Jenner's unregistered sale of securities in
6 violation of the Securities Act, Plaintiffs and other Class Members have suffered damages in
7 connection with their purchases or acquisitions of \$JENNER.

8 112. Jenner is liable to Plaintiffs and the Class pursuant to the Securities Act for
9 compensatory and equitable relief, including rescission or damages, together with pre- and
10 post-judgment interest, reasonable attorneys' fees, and costs of suit.

11 **SECOND CAUSE OF ACTION**

12 **False and Misleading Statements and Deceptive Omissions**

13 **In Violation of 12(a)(2) of the Securities Act**

14 **(Against Jenner)**

15 113. Plaintiffs reallege and incorporate the allegations elsewhere in the Complaint as
16 if set forth fully herein.

17 114. Section 12(a)(2) makes it unlawful to offer or sell a security by the use of a
18 means or instrumentality of interstate commerce by means of a prospectus or oral
19 communication that includes an untrue statement of material fact, or omits a material fact that
20 is necessary to make the statement, in light of the circumstances under which it was made,
21 not misleading. *See* 15 U.S.C. § 771(a)(2); *Miller v. Thane Int'l, Inc.*, 519 F.3d 879, 885 (9th
22 Cir. 2008).

23 115. Throughout the Class Period, Jenner offered and sold \$JENNER to Plaintiffs
24 and other Class Members by means of written and oral communications, including but not
25 limited to promotional material, social media posts, online advertisements, and public
26 statements.

27 116. These written and oral communications contained materially false and
28 misleading statements, and omitted material facts necessary to make the statements not

1 misleading, including but not limited to the following: (i) misrepresentations regarding the
2 potential profitability, functionality, and value of \$JENNER; (ii) failing to disclose the risks
3 associated with investing in \$JENNER, including regulatory risks and potential lack of
4 liquidity; (iii) misleading statements about the project's financial health, business prospects,
5 and future growth opportunities; (iv) Jenner's and other insiders' own holdings and financial
6 interests in the enterprise; and (v) false and misleading statements about getting \$JENNER
7 listed on CEXs.

8 117. Plaintiffs and other Class Members relied on these materially false and
9 misleading statements and omissions in deciding to purchase \$JENNER offered by Jenner.

10 118. As a direct and proximate result of Jenner's actions and omissions, Plaintiffs and
11 the Class have suffered damages in connection with their purchases of the securities.

12 119. Jenner is liable to Plaintiffs and the Class pursuant to the Securities Act for
13 compensatory and equitable relief, including rescission or damages, together with pre- and
14 post-judgment interest, reasonable attorneys' fees, and costs of suit.

15 **THIRD CAUSE OF ACTION**

16 **Securities Fraud**

17 **In Violation of 15 U.S.C. § 78j(b) and 17 C.F.R. § 240.10b-5(b)**

18 **(Against Jenner)**

19 120. Plaintiffs reallege and incorporate the allegations elsewhere in the Complaint
20 as if set forth fully herein.

21 121. Jenner, by use of the means instrumentalities of interstate commerce, in
22 connection with the purchase and sale of \$JENNER, made to Plaintiffs and other Class
23 Members, untrue statements of material fact, and omitted material facts, with the intent to
24 deceive.

25 122. At all times relevant to this action, Jenner was an international superstar
26 celebrity, enjoying widespread reputation and public image as having special and unique
27 influence on marketing and promotional gimmicks.

28

1 123. Jenner, by use of the means and instrumentalities of interstate commerce,
2 made false and misleading statements of then-existing fact and omissions of material fact in
3 connection with the purchase and sale of \$JENNER to investors and the public, including
4 Plaintiffs and other Class Members, from May 26, 2024, through at least September 2024,
5 thereby artificially inflating the price and/or value of \$JENNER.

6 124. Jenner made the aforesaid false and misleading statements and omissions
7 knowing they were false and deceptive.

8 125. Jenner, by use of the means and instrumentalities of interstate commerce, also
9 made false and misleading forward-looking statements to Plaintiffs, other Class Members,
10 investors, and the public, in connection with the purchase and sale of \$JENNER, from May
11 26, 2024 through the present, and continues to do so, thus artificially inflating the price and/or
12 value of \$JENNER.

13 126. Jenner made these false and misleading forward-looking statements while
14 simultaneously failing to make meaningful cautionary statements identifying important
15 factors then known to her that could cause actual results to differ materially from those in the
16 purported forward-looking statements.

17 127. Jenner made the aforesaid forward-looking statements knowing they were
18 false, but hoping that her public persona and online antics could make them true eventually.

19 128. Jenner, by her false and misleading public statements, knowingly and
20 recklessly lent \$JENNER a false character in commerce, namely as a potential to increase in
21 value, and falsely suggested her personality and online celebrity status could support and
22 propel the project indefinitely, thereby artificially inflating the price and/or value of
23 \$JENNER.

24 129. Jenner lent \$JENNER this false character with reckless disregard for whether
25 her personality and online celebrity status and antics could in fact support and propel such
26 long-term value.

27 130. Jenner by her false and misleading public statements knowingly and recklessly
28 lent \$JENNER a false character in commerce, namely, that of a fun, profitable and fungible

1 investment instrument on the cutting edge of technology and pop culture, thereby artificially
2 inflating the price and/or value of \$JENNER, while knowing countervailing information
3 about \$JENNER's risks that she failed to disclose or adequately disclose to Plaintiffs and the
4 Class.

5 131. Jenner's material misstatements and omissions concealed from Plaintiffs and
6 the Class \$JENNER's utter dependence on her public statements and online antics for its
7 value; the unsustainability of this support as a basis for \$JENNER's value; and the severe
8 extent to which \$JENNER is limited in its potential utility, fungibility, and sustainability as
9 an investment.

10 132. A primary purpose of Jenner's material misstatements and omissions was to
11 cross-promote herself and to cultivate a cryptocurrency brand uniquely associated with her
12 brand of celebrity, which she could leverage for financial gain, and which she in fact did
13 leverage for financial gain through deployment of her transaction tax on the Ethereum
14 blockchain.

15 133. If not for Jenner's material misstatements and omissions, Plaintiffs and other
16 Class Members would not have purchased \$JENNER.

17 134. During the Class Period, Plaintiffs and other Class Members, in reliance on
18 Jenner's material misrepresentations, purchased \$JENNER at artificially inflated prices
19 resulting from her misstatements and omissions.

20 135. As a direct and proximate result of Jenner's wrongful conduct in violation of
21 15 U.S.C. § 78j(b) and 17 C.F.R. § 240.10b-5(b), Plaintiffs and the Class suffered economic
22 loss in connection with their purchases of \$JENNER, and therefore are entitled to and do seek
23 damages and injunctive relief.

FOURTH CAUSE OF ACTION

Violation of Section 15(a) of the Securities Act

(Against Hutchins)

24
25
26
27 136. Plaintiffs reallege and incorporate the allegations elsewhere in the Complaint
28 as if set forth fully herein.

1 137. Given her interest and control over the \$JENNER project, Hutchins acted as a
2 controlling person of the \$JENNER project within the meaning of Section 15(a) of the
3 Securities Act.

4 138. By virtue of her position as “CEO” of, and participation in the \$JENNER
5 project’s operations, Hutchins had the power to influence and control, and did influence and
6 control, directly and indirectly, decision making relating to \$JENNER, including the decision
7 to engage in the fraudulent offer and sale of unregistered securities.

8 139. By virtue of the foregoing, Hutchins is liable to Plaintiffs and the Class as a
9 control person of the \$JENNER project under Section 15(a) of the Securities Act, and is
10 jointly and severally liable for any and all damages for which Jenner is liable under the
11 Securities Act.

12 **FIFTH CAUSE OF ACTION**

13 **Offer, Sale, or Purchase of Securities and Fraudulent or Misleading Actions**

14 **In Violation of California Corp. Code § 25401**

15 **(Against Jenner)**

16 140. Plaintiffs reallege and incorporate the allegations elsewhere in the Complaint as
17 if set forth fully herein.

18 141. California Corp. Code § 25401 prohibits fraud in the offer or sale of securities
19 by any person in California.

20 142. \$JENNER is a security under controlling federal law.

21 143. Jenner offered and sold \$JENNER in California by means of written and oral
22 communications that included an untrue statements of material facts and omitted material
23 facts necessary to make the statements, in the light of the circumstances under which they
24 were made, not misleading.

25 144. Jenner is liable to Plaintiffs and the Class pursuant to California Corp. Code §
26 25401 for compensatory and equitable relief, including rescission or damages, together with
27 pre- and post-judgment interest, reasonable attorneys’ fees, and costs of suit.
28

1 **SIXTH CAUSE OF ACTION**

2 **Offer and Sale of Unqualified Securities**

3 **In Violation of California Corp. Code § 25110**

4 **(Against Jenner)**

5 145. Plaintiffs reallege and incorporate the allegations elsewhere in the Complaint as
6 if set forth fully herein.

7 146. California Corp. Code § 25110 prohibits the offer or sale by any person in
8 California of securities that are not qualified through registration.

9 147. As described herein, \$JENNER is a security under controlling federal law.

10 148. Jenner offered and sold \$JENNER in California without being properly
11 registered or qualified for offer or sale with any federal or California regulator.

12 149. Jenner is liable to Plaintiffs and the Class pursuant to California Corp. Code §
13 25401 for compensatory and equitable relief, including rescission or damages, together with
14 pre- and post-judgment interest, reasonable attorneys' fees, and costs of suit.

15 **SEVENTH CAUSE OF ACTION**

16 **Common Law Fraud**

17 **(Against Jenner)**

18 150. Plaintiffs reallege and incorporate the allegations elsewhere in the Complaint
19 as if set forth fully herein.

20 151. Jenner intentionally and recklessly made material misstatements and
21 omissions of material fact to \$JENNER investors including Plaintiffs and other Class
22 Members.

23 152. Jenner, for personal financial benefit, made these misrepresentations to induce
24 Plaintiffs and other Class Members to purchase and hold \$JENNER, even as the value of the
25 security plummeted.

26 153. Plaintiffs and the Class reasonably relied on Jenner's misrepresentations to
27 purchase and hold \$JENNER.
28

1 154. Plaintiffs and the Class lost money purchasing and holding \$JENNER, when
2 Jenner’s misrepresentations turned out to be false.

3 155. As a direct and proximate result of Jenner’s fraud, Plaintiff and the Class
4 suffered economic loss and therefore are entitled to and do seek damages and injunctive relief,
5 including monies unlawfully or inequitably obtained by Jenner through the deployment of a
6 transaction tax on the Ethereum-based \$JENNER.

7 **EIGHTH CAUSE OF ACTION**

8 **Aiding and Abetting Fraud**

9 **(Against Hutchins)**

10 156. Plaintiffs reallege and incorporate the allegations elsewhere in the Complaint as
11 if set forth fully herein.

12 157. Under California law, “[l]iability may . . . be imposed on one who aids and abets
13 the commission of an intentional tort if the person (a) knows the other’s conduct constitutes
14 a breach of duty and gives substantial assistance or encouragement to the other to so act or
15 (b) gives substantial assistance to the other in accomplishing a tortious result and the person’s
16 own conduct, separately considered, constitutes a breach to the third person.” *Neilson v.*
17 *Union Bank of Cal., N.A.*, 290 F. Supp. 2d 1101, 1118 (C.D. Cal. 2003) (citations omitted).
18 “Unlike a conspirator, an aider and abettor does not ‘adopt as his or her own’ the tort of the
19 primary violator. Rather, the act of aiding and abetting is distinct from the primary violation;
20 liability attaches because the aider and abettor behaves in a manner that enables the primary
21 violator to commit the underlying tort.” *Id.*

22 158. By promoting \$JENNER on social media platforms, holding herself out as the
23 CEO of the \$JENNER project, and participating in the project’s management and decision
24 making, Hutchins provided assistance that was a substantial factor causing the price of
25 \$JENNER to surge and sustain long enough for Jenner to receive a significant amount of
26 revenue via transaction taxes on Ethereum. Moreover, because Hutchins made similar
27 misrepresentations and omissions concerning \$JENNER, her conduct breached a duty she
28

1 owed to Plaintiffs and other Class Members, to tell the full truth when soliciting their purchase
2 of securities.

3 159. Without Hutchins's assistance, Jenner would have been unable to use the
4 misleading marketing strategy she devised to fraudulently market \$JENNER, and would not
5 have been able to commit the violations of federal of state securities laws identified herein.

6 160. While giving Jenner assistance, Hutchins was aware Jenner was defrauding
7 Plaintiffs and other Class Members, because Hutchins and Jenner have both close business
8 and personal relationships. Moreover, by introducing Jenner to Arora to first mint \$JENNER,
9 Hutchins gave substantial encouragement to Jenner to commit the fraud.

10 161. Hutchins's substantial assistance and encouragement in the fraud caused
11 Plaintiffs and other Class Members to purchase and hold \$JENNER when they otherwise
12 would not have done so.

13 162. As a direct and proximate result of Hutchins aiding and abetting Jenner's fraud,
14 Plaintiffs and the Class suffered losses and are entitled to recover from Hutchins their actual
15 damages. Plaintiffs further seek an order enjoining Hutchin's wrongful acts or practices,
16 awarding restitution and disgorgement of all monies generated as a result of such practices,
17 and granting all other relief allowed under California law.

18 **NINTH CAUSE OF ACTION**

19 **Quasi Contract**

20 **(Against Jenner)**

21 163. Plaintiffs reallege and incorporate the allegations elsewhere in the Complaint
22 as if set forth fully herein.

23 164. Plaintiffs and other Class Members conferred direct monetary benefits on Jenner
24 in the form of fees paid for transaction taxes on the Ethereum-based \$JENNER.

25 165. With their money, Jenner unjustly enriched herself.

26 166. Jenner has knowledge of the benefits that Plaintiffs and other Class Members
27 conferred on her.
28

1 167. Under principles of equity and good conscience, Jenner should not be permitted
2 to retain the funds and assets she received as a result of her inequitable conduct.

3 168. To the extent that Plaintiffs and other Class Members have no other adequate
4 remedy at law, Plaintiffs seeks restitution of all funds and assets that Jenner has unjustly
5 received as a result of her wrongful charge, use, and conversion of transaction taxes on
6 Ethereum-based \$JENNER.

7 **PRAYER FOR RELIEF**

8 169. WHEREFORE, Plaintiffs, individually, and on behalf of all others similarly
9 situated, pray for judgment against Defendants as to each and every cause of action, and an
10 Order:

- 11 a. Declaring this action to be a proper class action, appointing Plaintiffs as
12 Class Representatives, and appointing their counsel as Class Counsel;
- 13 b. Requiring Defendants to bear the cost of Class Notice;
- 14 c. Requiring Defendants to pay compensatory, statutory, and punitive
15 damages permitted by law;
- 16 d. Requiring Defendants to disgorge all monies, revenues, and profits
17 obtained by means of any unlawful act or practice;
- 18 e. Awarding pre- and post-judgment interest on any monetary judgment;
- 19 f. Granting appropriate injunctive and declaratory relief;
- 20 g. Awarding reasonable attorneys' fees and costs; and
- 21 h. Granting such further relief that the Court deems necessary, just, and
22 proper.

23 **DEMAND FOR JURY TRIAL**

24 170. Plaintiffs hereby demand a jury trial for all claims so triable.

25
26 Dated: November 13, 2024

/s/ Jack Fitzgerald

27 **FITZGERALD MONROE FLYNN PC**
28 **JACK FITZGERALD**

jfitzgerald@fmfpc.com
MELANIE R. MONROE
mmonroe@fmfpc.com
TREVOR FLYNN
tflynn@fmfpc.com
PETER GRAZUL
pgrazul@fmfpc.com
2341 Jefferson Street, Suite 200
San Diego, California 92110
Counsel for Plaintiffs

1
2
3
4
5
6
7
8
9
10
11
12
13
14
15
16
17
18
19
20
21
22
23
24
25
26
27
28